



Data Sheet

---

## **AS1124**

24W, Powered Device with  
Integrated DC-DC Controller

Revision 1.1, May 2007

*Confidential and Proprietary*

## CONTENTS

General Description .....	1
Features .....	1
Typical Applications .....	1
Example Application .....	1
Connection Diagram .....	2
Pin Descriptions .....	2
Absolute Maximum Ratings .....	3
Normal Operating Conditions .....	3
Key Electrical Characteristics .....	4
Typical Performance Characteristics .....	6
Functional Description .....	9
Overview of PoE .....	9
The AS1124 PoE Design .....	9
Power Feed Alternatives for 10/100 Systems .....	10
AS1124 Overview .....	11
Rectification & Protection .....	11
PD Controller .....	11
Modes of Operation .....	11
Reset .....	11
Signature Detection Mode .....	11
Classification Mode .....	11
Idle Mode .....	13
ON State .....	13
PD Control Power and Thermal Protections .....	13
Under Voltage Lockout (UVLO) .....	13
Inrush Current Operation .....	14
Current Limit/Current Sense .....	14
Thermal Limit Protection .....	14
DC-DC Controller .....	14
Overview .....	14
Current-Limit/Current Sense .....	14
Low Load Current Operation .....	14
Compensation and Feedback .....	14
Soft-Start inrush current limit .....	14
Auxiliary Power Option .....	14
DC-DC Converter Topologies .....	14
Flyback vs. Forward Operation .....	14
Buck Operation .....	15
Primary Switching Topology .....	15
Thermal De-rating and Board Layout Considerations .....	15
Application Circuits .....	16
Physical Dimensions .....	20
Notes .....	21
Contact Information .....	22
Important Notices .....	22
Legal Notice .....	22
Life and Safety Policy .....	22

**GENERAL DESCRIPTION**

The AS1124 is a single-chip, highly integrated CMOS solution for Power over Ethernet (PoE). Applications include Voice over IP (VoIP) Phones, Wireless LAN Access Point, Security and Web Cameras, Analog Telephone Adapters (ATA) and Point of Sales Terminals.

The AS1124 provides the functions required for power over Ethernet Powered Device (PD) applications.

The AS1124 integrates rectification and protection circuitry, a PD controller, and a DC-DC converter. This high level of integration provides faster response to surge events and limits stray surge current from passing through sensitive circuits, such as the Ethernet PHY device. The device is designed to provide a safe low impedance discharge paths directly back to the earth ground, resulting in superior reliability and circuit protection.

AS1124 has been architected and designed to address both EMI emission concerns and surge/over-voltage protection in POE applications. AS1124 implements many design features that minimizes transmission of system common-mode noise on to the UTP while providing high immunity to over-voltage and surge events.

By using high-volume standard CMOS technology, Akros enables its customers to implement higher performance PoE devices with low cost and a small footprint.

**FEATURES**

The AS1124 is fully integrated and architected at a system level to provide the following features:

- Fully supports *IEEE*<sup>®</sup> Std. 802.3af-2003 and supports pre-standard *IEEE*<sup>®</sup> Std. 802.3at-2006 power requirements
- Meets IEC 61000-4-2/3/4/5/6 requirements
- Meets IEC 60950 over-voltage protection requirements
- Integrated rectification for superior high voltage protection
- Integrated DC-DC converter, provides exceptional EMI performance
- Programmable DC current limit up to 800 mA
- Supports “two finger” classification for pre-standard *IEEE*<sup>®</sup> Std. 802.3at-2006 higher power PD applications
- Provides seamless support for local power
- Over temperature protection
- 5x5 mm, 20 lead QFN Package, RoHS compliant

**TYPICAL APPLICATIONS**

- Pan, Tilt and Zoom (PTZ), security and Web Cameras
- Voice over IP (VoIP) phones
- Wireless LAN Access Points
- Analog Telephone Adapters (ATA)
- Point of Sale (PoS) Terminals

**EXAMPLE APPLICATION**

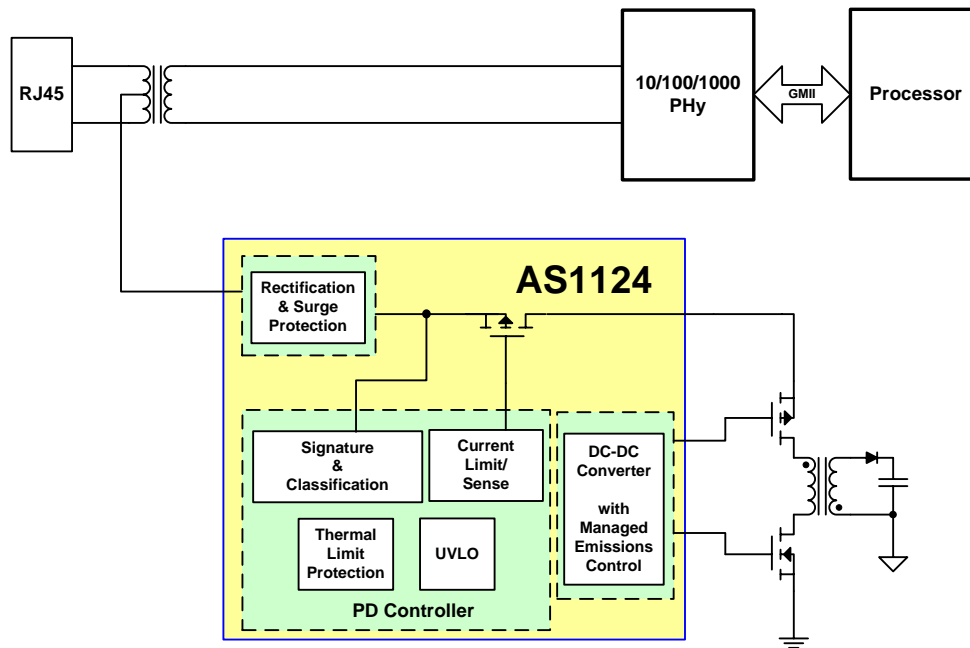
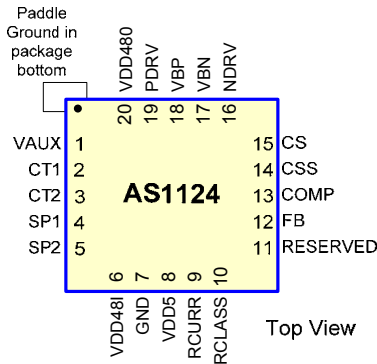

Figure 1. Typical Application Diagram for Gigabit Ethernet based PD (Flyback Converter)

CONNECTION DIAGRAM



PIN DESCRIPTIONS

Table 1. Pin Assignments			
Pin	I/O	Name	Description
1	P	VAUX	Auxiliary supply input
2	P	CT1	High voltage supply transformer center tap input. Polarity insensitive.
3	P	CT2	High voltage supply transformer center tap input. Polarity insensitive.
4	P	SP1	High voltage supply from spare pair. Polarity insensitive.
5	P	SP2	High voltage supply from spare pair. Polarity insensitive.
6	O	VDD48I	Internal 48V bus pin. This pin is the positive bus after the input diode bridge. The bus is brought out to a pin for the connection of an external ESD capacitor (82nF) and signature resistor (26.7k Ω).
7	I	GND	Must be connected to paddle ground (GNDA).
8	O	VDD5	Internal 5 volts decoupling point
9	A	RCURR	Current limit programming pin
10	A	RCLASS	Classification resistor connection
11	-	RESERVED	Open or connect to GND through 100k resistor
12	A	FB	DC-DC Controller feedback point
13	A	COMP	DC-DC Controller error amplifier compensation network connection
14	A	CSS	DC-DC Controller soft-start capacitor
15	A	CS	DC-DC Controller peak current sense input (low side)
16	O	NDRV	DC-DC Controller N-MOSFET gate drive
17	O	VBN	DC-DC Controller low side supply decoupling
18	O	VBP	DC-DC Controller high side supply decoupling
19	O	PDRV	DC-DC Controller P-MOSFET gate drive
20	P	VDD48O	Switched 48V supply output
Paddle	P	GNDA	Local analog ground. This is the negative output from the diode bridge, and is not isolated from the line input

Key:

I = Input

O = Output

I/O = Bidirectional

PD = Internal pull-down

A = Analog signal

P = Power

## ABSOLUTE MAXIMUM RATINGS

Table 2. Absolute Maximum Ratings <sup>1</sup>		
Description	Max Value	Units
High voltage pins (1—VAUX; 2 & 3—CT1 and 2; 4 & 5—SP1 and 2; 6—VDD48I; 18—VBP; 19—PDRV; 20—VDD48O)	60	Volts
Low voltage pins ( 8—VDD5; 9-RCURR; 10—RCLASS; 12—FB; 13—COMP; 14—CSS; 15—CS; 16—NDRV; 17—VBN)	6	Volts
ESD Rating:		
<i>Human body mode<sup>P</sup></i>	2	kV
<i>ESD charged device model</i>	500	V
<i>System level (contact/air) at RJ-45</i>	8/15	kV
Temperature		
<i>Storage Temperature</i>	165	°C
<i>Junction Temperature</i>	150	°C

<sup>1</sup> Absolute maximum ratings are limits beyond which damage to the device may occur.

<sup>2</sup> The human body model is as described in JESD22-A114.

## NORMAL OPERATING CONDITIONS

Table 3. Normal Operating Conditions			
Unless otherwise noted, specifications are for $T_a = +25^\circ\text{C}$ and $V_{in} = 48\text{V}$ .			
Description	Min	Typical <sup>1</sup>	Max
$V_{in}$	36V	48V	57V
Operating temperature range	0C		70°C

<sup>1</sup> Typical specification; not 100% tested. Performance guaranteed by design and/or other correlation methods.

## KEY ELECTRICAL CHARACTERISTICS

Table 4. Electrical Characteristics

Unless otherwise noted, specifications are for  $T_a = +25^\circ\text{C}$  and  $V_{in} = 48\text{V}$ .

	Min	Typical <sup>1</sup>	Max	Units	Comments
<b>PD Section</b>					
Inrush Current Limit		200		mA	
Current limit			800	mA	
Max. operating current		625		mA	
Switch On Resistance, $R_{DS-ON}$		1.25	1.50	$\Omega$	
Diode bridge $V_f$ forward voltage		900		mV	Single diode drop. Total bridge voltage drop includes 2 diodes.
Reset voltage level	0		2.7	V	
Min Signature voltage			2.7	V	
Max Signature voltage	10.1		14.5	V	
Min Classification voltage			14.5	V	In classification, the AS1124 sinks current as defined in table 5
Max Classification voltage	20.5			V	
Full power activation threshold	42			V	
Full power de-activation threshold			36	V	
Auxiliary power input voltage range	42		57	V	Auxiliary power applied between VAUX and GNDA. Applying power at both auxiliary and line inputs is not recommended. If both sources are present, the larger voltage will be used.
<b>DC-DC Controller Section</b>					
Output voltage range	3.3	12	15	V	Adjustable via transformer design from 3.3V to 15V (See Akros Application Notes for recommended transformers)
$F_{OSC}$ (SMPS) switching frequency	325	350	375	kHz	Controller operating frequency
$F_{OSC}$ Temperature Coefficient		0.12		%/C	
PDRV $R_{OUT}$		1.5	4.5	$\Omega$	High side output drive resistance
NDRV $R_{OUT}$		1.2	3	$\Omega$	Low side output drive resistance
PDRV and NDRV Gate Drive $V_{OH} - V_{OL}$	4.5		6	V	
Gate Drive Dynamic Response PDRV $T_R, T_F$ NDRV $T_R, T_F$		2.2 2		nS nS	10% - 90% with $C_{Load} = 1\text{ nF}$
Max. load power		20		W	Conditions: $V_{out}=12\text{V}$ , $V_{in}=48\text{V}$
$V_{PK}$ , peak current sense threshold voltage at CS	500	600	700	mV	$I_{peak}=V_{pk}/R_{sense}$
Max. duty cycle		80		%	Internally limited
Min. duty cycle		6		%	Internally limited

**Table 4. Electrical Characteristics**Unless otherwise noted, specifications are for  $T_a = +25^\circ\text{C}$  and  $V_{in} = 48\text{V}$ .

	Min	Typical <sup>1</sup>	Max	Units	Comments
VBN		4.7		V	Low side internal supply voltage; sets $V_{OH}$ of NDRV.
VBP (relative to VDD480)		-5		V	High side internal supply voltage; sets $V_{OL}$ of PDRV.
Slope compensation		90		mV	Internal slope compensation peak ramp voltage
Soft start ramp time		2		ms	Conditions: $CSS=100\text{nF}$
COMP source current		30		$\mu\text{A}$	$FB = 0\text{V}$ , $COMP=0\text{V}$
COMP sink current		30		$\mu\text{A}$	$FB = 5\text{V}$ , $COMP=5\text{V}$
Open loop voltage gain		80		dB	
Small signal unity gain bandwidth		5		MHz	COMP connected to FB.
FB leakage (source or sink)		1		$\mu\text{A}$	$0\text{V} > FB > 4.5\text{V}$
<b>Thermal Protection</b>					
Thermal shutdown temperature		165		$^\circ\text{C}$	Above this Temp., the AS1124 is disabled.
Max. on-die operating temperature		140		$^\circ\text{C}$	
Current reduction temperature threshold		145		$^\circ\text{C}$	Temperature at which thermal current reduction is applied
Thermal current reduction		50		%	
Thermal current reduction hysteresis		20		$^\circ\text{C}$	Temperature change required to restore full operation after thermal current reduction
Thermal shutdown hysteresis		40		$^\circ\text{C}$	Temperature change required to restore full operation after thermal shutdown

<sup>1</sup> Typical specifications are not 100% tested. Performance guaranteed by design and/or other correlation methods.**Table 5. Package Thermal Characteristic**

	Min	Typical <sup>1</sup>	Max	Units	Comments
Thermal Resistance, Junction to Ambient, $^1 \theta_{JA}$		31		$^\circ\text{C}/\text{W}$	20 lead QFN package
Power dissipation, $P_{DISS}$		2.4		W	24W Operation, (12V output at 1.7A)

TYPICAL PERFORMANCE CHARACTERISTICS

DC Current Limit vs. Junction Temperature<sup>1</sup>

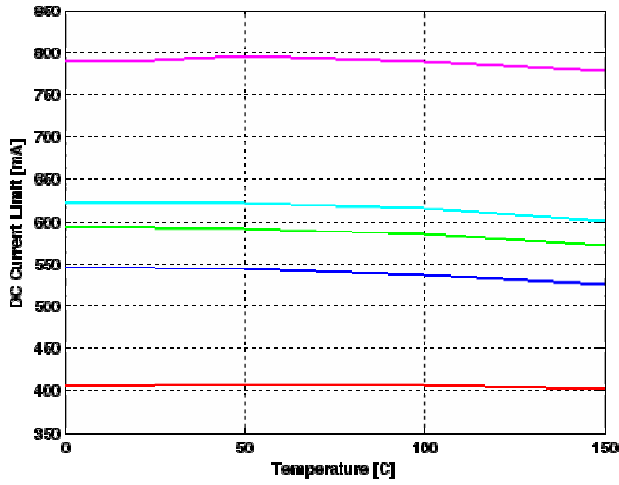

Full Load Diode Bridge  $V_F$  vs. Junction Temperature

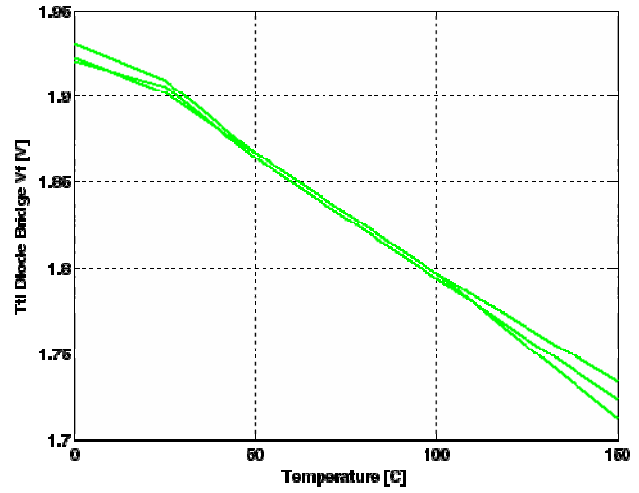

Switch  $R_{ON}$  vs. Junction Temperature (Min/Max  $V_{IN}$ )

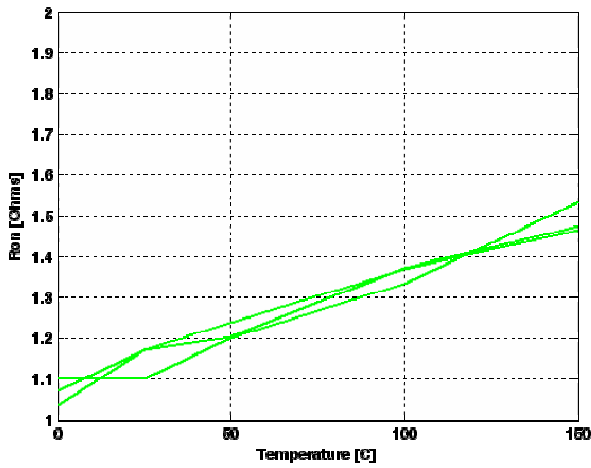

Error Amplifier  $V_{REF}$  vs. Junction Temperature

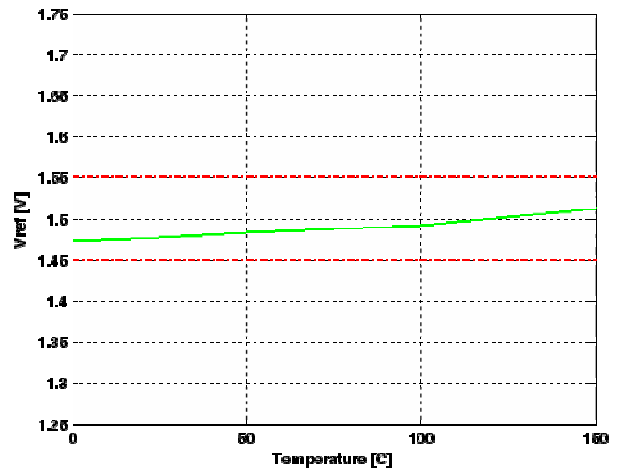

<sup>1</sup> Current limit measured with  $R_{CURR}=0, 27k\Omega, 47k\Omega, 67k\Omega$  and open circuit



VDD5 vs. Junction Temperature

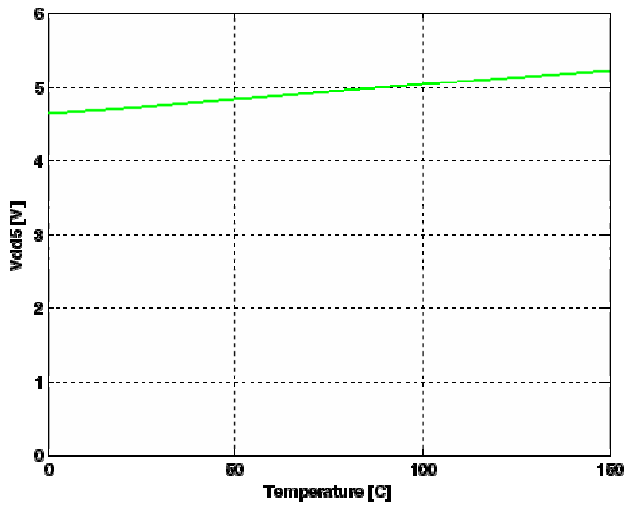

VBN & VBP (wrt VDD480) vs. Junction Temperature

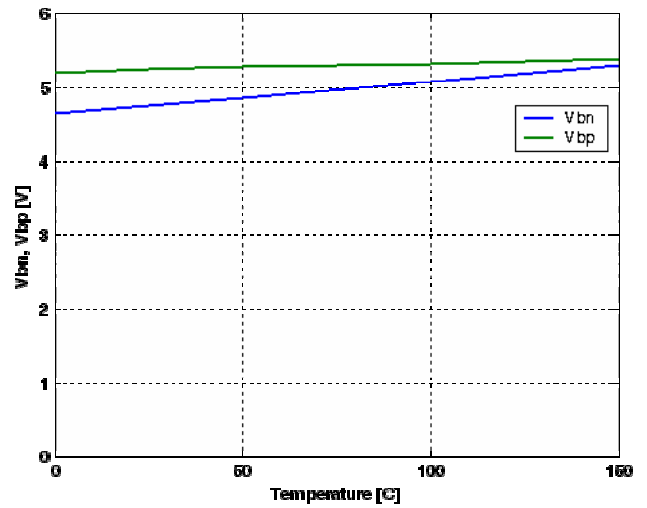

VDD5 vs. Vin

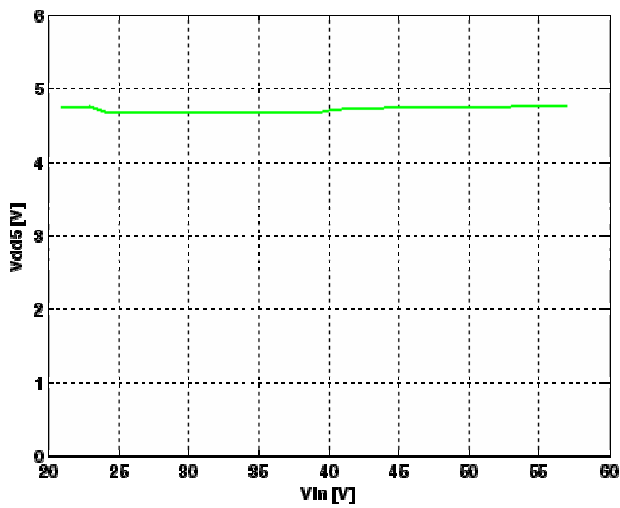

VBN & VBP (VBP wrt VDD480) vs. Vin

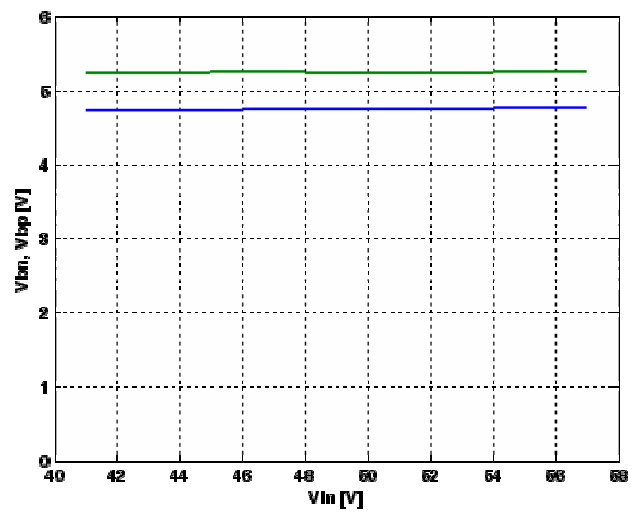

DCDC Load Regulation vs.  $I_{OUT}$  @  $V_{IN}=48V, V_O = 12V$

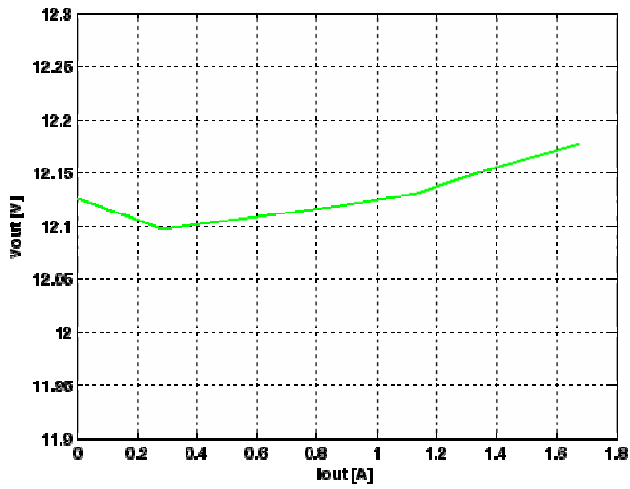

DCDC Line Regulation @  $I_{OUT}=0.25A$

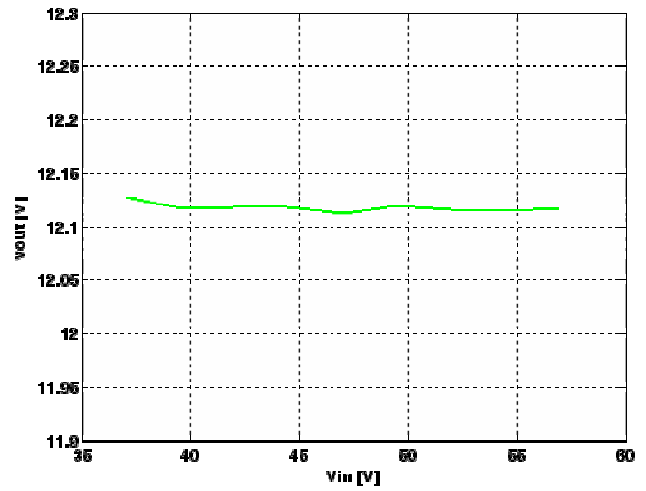

DCDC Efficiency vs.  $I_{OUT}$  @  $V_{IN}=48V, V_O = 12V$

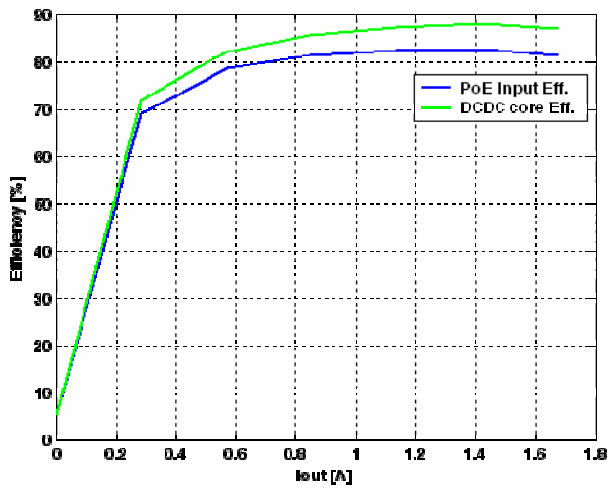

DCDC Efficiency vs.  $P_{OUT}$  @  $V_{IN}=48V$

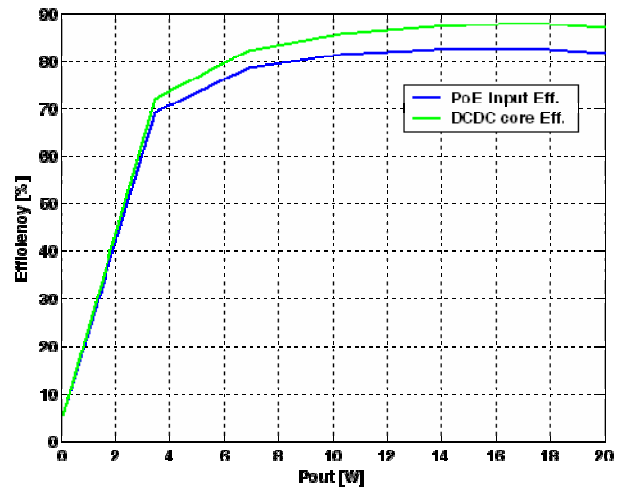

## FUNCTIONAL DESCRIPTION

### OVERVIEW OF POE

Power over Ethernet (PoE) offers an economical alternative for powering end network appliances such as IP telephones, wireless access points, security and web cameras, and other powered devices (PDs). The PoE standard *IEEE®* Std. 802.3af-2003 is intended to standardize the delivery of power over the Ethernet cables in order to accommodate remotely powered client devices. *IEEE®* Std. 802.3af-2003 defines a method for recognizing PDs on the network and supplying different power levels according to power level *classes* with which each PD is identified. By employing this method, designers can create systems that minimize power usage, allowing more devices to be supported on an Ethernet network.

The end of the link that provides power through the Ethernet cables is referred to as the power sourcing equipment (PSE). The powered device (PD) is the end of the link that receives the power. The PoE method for recognizing a PD and determining the correct power level to allocate uses the following sequence:

- *Reset*, wherein power is withdrawn from the PD if the applied voltage falls below a specified level.
- *Signature Detection*, during which the PD is recognized by the PSE.
- *Classification*, during which the PSE reads the power requirement of the PD. The Classification level of a PD identifies how much power the PD requires from the Ethernet line. This permits optimum use of the total power available from the PSE. (Classification is considered optional by *IEEE®* standard 802.3af-2003.)
- *ON* operation, during which the allocated level of power is provided to the PD.

This sequence occurs as progressively rising voltage levels from the PSE are detected.

To design PoE systems according to the PoE standard, designers have the following constraints:

Table 6. PoE Requirements	
Requirement	Value
Maximum power to the PD-PI	26W
Voltage from PSE	44-57V
Maximum operating current	800mA
Line resistance	14.1 $\Omega$
Voltage drop due to series line resistance	8.8V
Min voltage at PD interface	36V

### AS1124 PoE DESIGN

To help designers meet these requirements, the AS1124 is a fully integrated PoE PD controller. The AS1124 meets all system requirements for the *IEEE®* 802.3 standard for Ethernet and all power management requirements for *IEEE®* standard 802.3af-2003. The device has been designed to also address pre-standard 802.3at applications. EMI compliance has been verified for FCC, Cisper 22 class B radiated emissions and EN55022 conducted emissions.

The AS1124 acts as an interface to the PSE, performing all detection, classification, and inrush current limiting control necessary for compliance with the PoE standards. An internal MOSFET and control circuit limits the inrush and steady-state current drawn from the Ethernet line. An integrated diode bridge is implemented to protect against polarity reversal, to provide alternative A and B detection and to provide improved high voltage protection. The AS1124 passes 2kV ESD tests. The AS1124 passes 2kV ESD tests, as well as 8kV Contact Discharge and 15 kV air Discharge tested per IEC 61000-4.2, 4.4,4.5.

**Power Feed Alternatives for 10/100 Systems**

Figure 2 illustrates the two power feed options allowed in the 802.3af standard for 10/100 systems. In Alternative A, a PSE powers the end station by feeding power along the twisted pair cable used for the 10/100 Ethernet signal via the center taps of Ethernet transformers. On the line side of the transformers for

the PD, power is delivered through pins 1 and 2 and returned through pins 3 and 6. In Alternative B, a PSE powers the end station by feeding power through the cable pairs not used for 10/100 data transmission. Power is delivered through pins 4, 5, 7 and 8 without transformers.

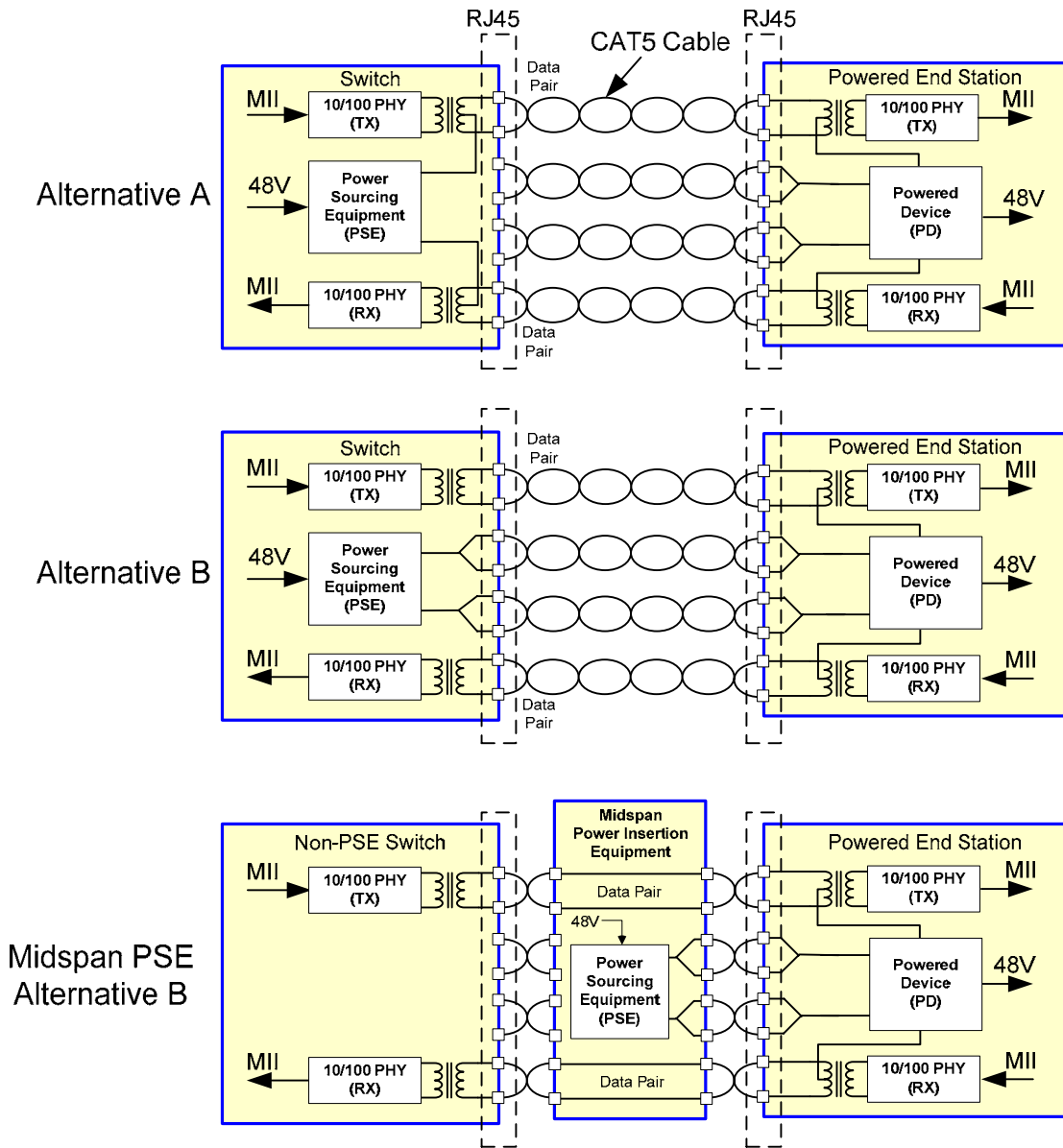

Figure 2. IEEE® Std. 802.3af-2003 Power Feeding Schemes for 10/100 Systems

The IEEE® Std. 802.3af-2003 is intended to be fully compliant with all existing non-powered Ethernet systems. As a result, the PSE is required to detect via a well-defined procedure whether or not the

connected device is PD compliant and classify the needed power prior to applying power to the system. Maximum allowed voltage is 57V to stay within SELV (Safety Extra Low Voltage) limits.

## AS1124 OVERVIEW

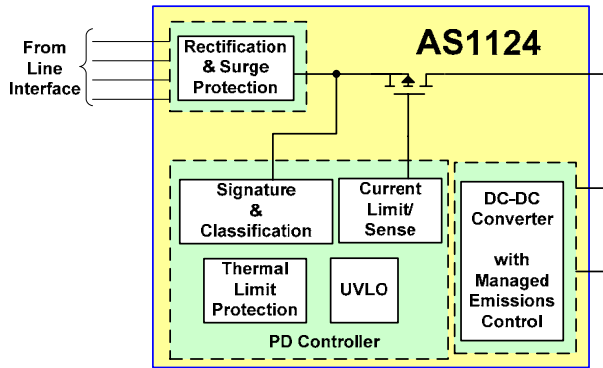

Figure 3. Top-Level Block Diagram of the AS1124

The AS1124 is a fully integrated PD that provides the functions required for power over Ethernet (PoE) applications. The optimized architecture of the AS1124 reduces external component cost in a small footprint while delivering high performance.

## RECTIFICATION & PROTECTION

To protect against polarity reversal and provide automatic polarity correction, the AS1124 includes an integrated bridge for rectification, with over voltage and transient protection, before passing to the switch and DC-DC controller.

By Integrating the diodes and protection circuitry, Akros has produced a solution that provides a much faster response to surge events. The design limits stray surge current from passing through sensitive circuits, such as the Ethernet PHY device and enables a low impedance safe discharge paths directly back to the earth ground. The protection circuit itself is carefully designed to ensure that during these surge events, where currents can sometime be as high as 30A, that voltages do not exceed critical breakdown and spark gap limits so they themselves are not destroyed by the event.

## PD CONTROLLER

The AS1124 PD Control interface is designed to provide full PD functionality for IEEE 802.3af compliant systems, with programmable support for the standard PD control functions.

The PD Control provides the following major functions:

- Provides a resistance for signature detection.
- Provides classification currents for power classification.
- Provides PD full power.
- Manages power and thermal protection overrides, including UVLO (under voltage lockout).

## Modes of Operation

The AS1124 has five operating modes:

1. Reset—the classification state machine is reset, and all blocks are disabled.
2. Signature Detection —The PD signature resistance is applied across the input.
3. Classification—PD indicates power requirements to the PSE.
4. Idle—This state is entered after classification, and remains here until full-power input voltage is applied.
5. ON—The PD is enabled, and supplies power to the DC-DC controller and the local application circuitry.

As the supply voltage from the PSE increases from 0V, the AS1124 transitions through the modes of operation in this sequence:

Reset ⇌ Signature Detection ⇌ Classification ⇌ Idle ⇌ ON

If no PSE is present, line voltage will be zero, which will hold the AS1124 in the reset state, and the AS1124 does not affect the Ethernet link function.

### Reset

When the voltage supplied to the AS1124 drops below the signature voltage range (i.e. <2.7V), the chip will enter the reset state. In the reset state, the AS1124 consumes very little power, the power supply to the PD is disconnected, and conditions revert to pre-classification.

### Signature Detection Mode

During signature detection, the PSE applies a voltage to the AS1124 PD to read its power signature. The reading of the signature determines whether or not a PD is present and, if so, allows the PSE to determine the power class the PD belongs to.

To detect a PD, the PSE applies two voltages in the signature voltage range, and extracts a signature resistance value from the I-V slope. Valid resistance (I-V slope) values are between 23.75kΩ and 26.25kΩ. For the AS1124, signature resistance is generated by an external resistor between VDD48I and GNDA. Typically this is a 26.7kΩ, 1% resistor.

### Classification Mode

Each class represents a power allocation level for a PD, so that PSE can manage power between multiple PDs. IEEE® Std. 802.3af-2003 defines classes of power levels for PDs as shown in Table 7. The AS1124 supports “two finger” classification for pre-standard IEEE® Std. 802.3at-2006 as shown in Figure 4.

To classify the PD, the PSE presents a voltage between 14.5V and 20.5V to the PD and determines its class by measuring the load current the PD sinks.

The AS1124 allows the user to program the classification current via an external resistor in the RCLASS pin. Current, power levels and programming resistor values for each class are shown in Table 7.

Use the following equation to determine typical classification current:

- $I_{CLASS} [mA] = 2.0 + \frac{2360}{R_{CLASS} [k\Omega]}$
- Tolerance = Maximum of  $\pm 1.8mA$  or  $\pm 9\%$
- $R_{CLASS} > 63.4k\Omega$

Table 7. Classification Map			
Class	Power (Watts)	Iclass	Rclass
0	0.44-12.95	0-4 mA	Pull-up, 1%
1	0.44-3.84	9-12 mA	280k $\Omega$ , 1%
2	3.84-6.49	17-20 mA	143k $\Omega$ , 1%
3	6.49-12.95	26-30 mA	90.9k $\Omega$ , 1%
4	Reserved	36-44 mA	63.4k $\Omega$ , 1%

PoE Power-On Startup Waveform

Figure 4 represents the power-on sequence for PoE operation. The waveform reflects typical voltages present at the PD-PI during signature, classification and power-on.

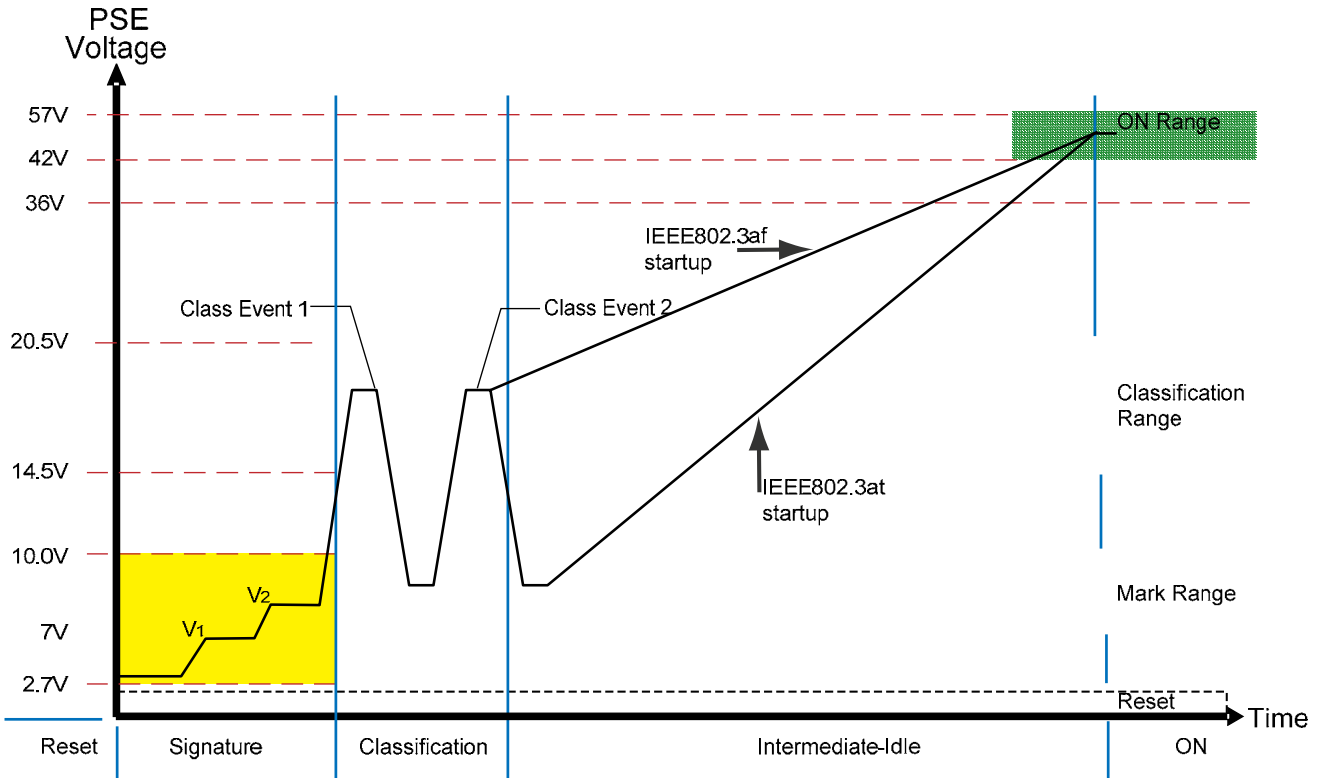

Notes

1. Voltages V1 and V2 are applied by a PSE to extract a signature resistance value.
2. The PSE takes current readings during Class Events to determine the class of the PD. At this time, the PD presents a load current determined by the resistance on the RCLASS pin.
3. After the PSE measures the PD load current, if it is a high power PSE it presents a mark voltage (between 7V and 10V) followed by a second classification. The PD responds by presenting a load current as determined by the resistor on the RCLASS pin. After the PSE measures the PD load current the second time, and determines that it can deliver the requested power, it moves into the ON state by raising the voltage above 42V.

Figure 4. Representative Power-On waveform

Idle Mode

In the Idle mode, between Classification and the ON state, PD Current is limited to monitoring circuitry to detect the on-state threshold.

ON State

In the ON state, the AS1124 is supplying power.

At a voltage at or above 42V, the PD turns on and full power is available via the AS1124 DC-DC Controller.

PD CONTROL POWER AND THERMAL PROTECTIONS

The AS1124 provides the following PD control power and thermal protections:

- Under Voltage Lockout (UVLO)
- Current Limit with integrated current sense
- Thermal Limit/Protection

Under Voltage Lockout (UVLO)

The AS1124 contains a line Under-Voltage Lockout (UVLO) circuit. The UVLO circuitry detects conditions when the supply

voltage is too low (less than 36V), and disconnects the power to protect the PD.

### Inrush Current Operation

Inrush limiting maintains the cable voltage above the turn-off threshold as the input capacitor charges. Also, it helps prevent the PSE from going into current limit mode.

### Current Limit/Current Sense

The Current Limit/Current Sense circuitry minimizes on-chip temperature peaks by limiting inrush current and operating current. It monitors the current via an integrated sense circuit and regulates the gate voltage on an integrated low-leakage 80V power MOSFET. In addition, the power MOSFET can be shut down by the PD Controller subsection or the Thermal Limit Protection subsection.

### Thermal Limit Protection

The AS1124 provides thermal protection for itself by monitoring die temperature and reducing maximum current or disconnecting power as needed to prevent pre-set thermal limits from being exceeded.

Two-stage thermal current limiting is implemented, which reduces the operating current limit by 50% when the die temperature reaches 145°C, and disables the power MOSFET switch above 165°C. Normal current limits in both cases are reapplied when the die temperature returns to 125°C.

## DC-DC CONTROLLER

### Overview

The DC-DC architecture is a current-mode controller which can be configured with external component changes to flyback, forward, or non-synchronous low-side switch buck topologies. Both non-isolated and isolated topologies are supported.

As part of full system level solution for EMI, Akros has focused significant effort in reducing switching noise in the integrated power converters through unique techniques of balancing the signaling of the FET drivers and reducing ground bounce by minimizing the dV/dt switching noise.

The integrated DC-DC controller operates from a switched input voltage (VDD480) and includes soft-start and current limiting. Once input power is applied and enable signals are asserted, the DC-DC controller starts up. The controller provides gate control signals to external switching MOSFETs, and uses an external resistor to sense the transformer primary current.

The DC-DC controller includes programmable soft start, 80%

maximum duty cycle, fixed switching frequency and a true voltage output error amplifier.

### Current-Limit/Current Sense

The DC/DC controller provides cycle-by-cycle current limiting to ensure that transformer primary current limits are not exceeded. In addition, the maximum average current in the transformer primary is set by internal duty cycle limits.

### Low Load Current Operation

The internal circuitry detects a low output power condition and puts the DC-DC Controller into a discontinuous current operation (DCM) mode.

### Compensation and Feedback

For isolated applications, loop compensation and output voltage feedback is generally provided by an opto-isolator circuit, and the FB pin is shorted to ground. In these applications, the COMP pin is pulled up to 4.8V (nominally) by an internal current source. This pull-up can be the termination for an opto-isolator, or an additional resistor can be used in parallel.

For non-isolated applications, a resistive divider network senses the output voltage and is applied directly to the FB pin. The internal error amplifier is connected to a 1.5V reference voltage and the control loop will servo the FB pin to this voltage. A capacitive/resistive network connected to the COMP pin provides loop compensation.

### Soft-Start inrush current limit

The internal circuitry automatically ramps up the inrush current by limiting the maximum current allowed in the transformer primary magnetizing inductance per clock cycle. The amount of time required to perform a soft start cycle is determined by the CSS capacitor. A CSS capacitor of 330nF provides approximately 7ms of soft startup ramp time.

## AUXILIARY POWER OPTION

The Auxiliary Power Option allows the AS1124 to be powered from a source other than the Ethernet line, such as AC adapters, batteries, or solar cells. This feature may be used, for example, to supply power that exceeds the load capacity of the PSE, or in non PoE systems.

## DC-DC CONVERTER TOPOLOGIES

### Flyback vs. Forward Operation

The DC-DC controller can be configured in several different operational topologies and in either isolated or non-isolated configurations. The FLYBACK mode is chosen when a minimum of external component is desired. However the FLYBACK mode exhibits larger output noise, is not as efficient and delivers less power than the FORWARD mode operation.



The FLYBACK mode is shown in figure 5 and the FORWARD mode in shown in figure 6, both in isolated configurations.

**Buck Operation**

The BUCK mode is shown in figure 7. The buck mode can only be used in non-isolated applications. The BUCK mode uses an inductor instead of a transformer and therefore has the smallest overall footprint. Figure 7 shows the BUCK converter in a non synchronous operation where the output voltage is referenced to VDD480. Since the FB voltage is ground referenced, the feedback signal must be level shifted back down to ground. This is accomplished by the two PNP transistors and the associated resistors. The level shifter adds an additional error to the feedback signal which reduces somewhat the output accuracy.

**Primary Switching Topology**

The DC-DC controller uses a two-switch topology to minimize noise, maximize efficiency and reduce the breakdown requirements for the switching transistors. During OFF time and when the core is being reset, the parallel Schottky diodes carry the transformer magnetizing current and recycle it back into the bulk storage capacitors connected to VDD480. This configuration does not require a separate snubbing circuit or reset winding which significantly reduces primary side ringing and keeps the maximum voltage across either switch to  $V_{DD480} + 2 V_F$ . In single switch topologies, the maximum  $V_{DS}$  is approximately 2.5X VDD480 and there is significant ringing during OFF time when the core is being reset. This increases noise and reduces efficiency.

**Thermal De-rating and Board Layout Considerations**

The AS1124 package uses an integral thermal pad to help dissipate heat from the switch and diode bridge. In higher power applications, designers must consider thermal design as an integral part of their systems design and remove heat via this pad.

Under 802.3af power considerations, the As1124 is capable of operating to industrial ambient air temperatures, or 85C. Under increased power, the operating temperature must be de-rated according to Figure 5 below.

The limits for the power de-rating are a max  $T_{J(MAX)}=145^{\circ}C$  and a  $\theta_{JA}=31^{\circ}C/W$ , which is achievable in the JEDEC airflow environment by the 20-pin 5x5mm QFN package.

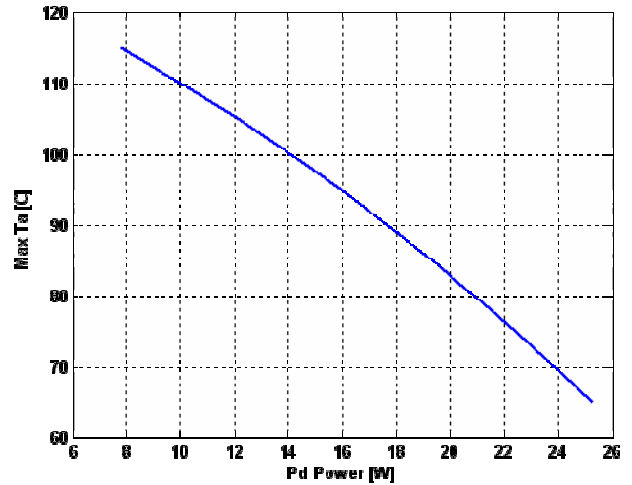

Figure 5. Thermal de-rating for high power operation

For adequate heat dissipation, the board layout must include a ground pad which accomplishes both the ground connection and provides a path for heat to flow to the board ground.

A typical PCB layout for the AS1124 is shown in Figure 6 below.

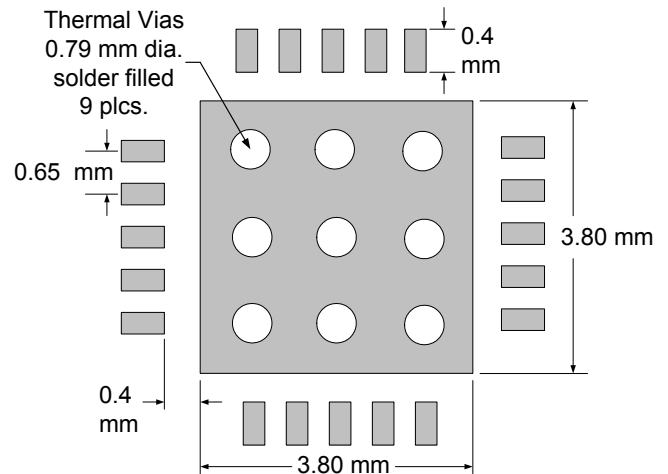
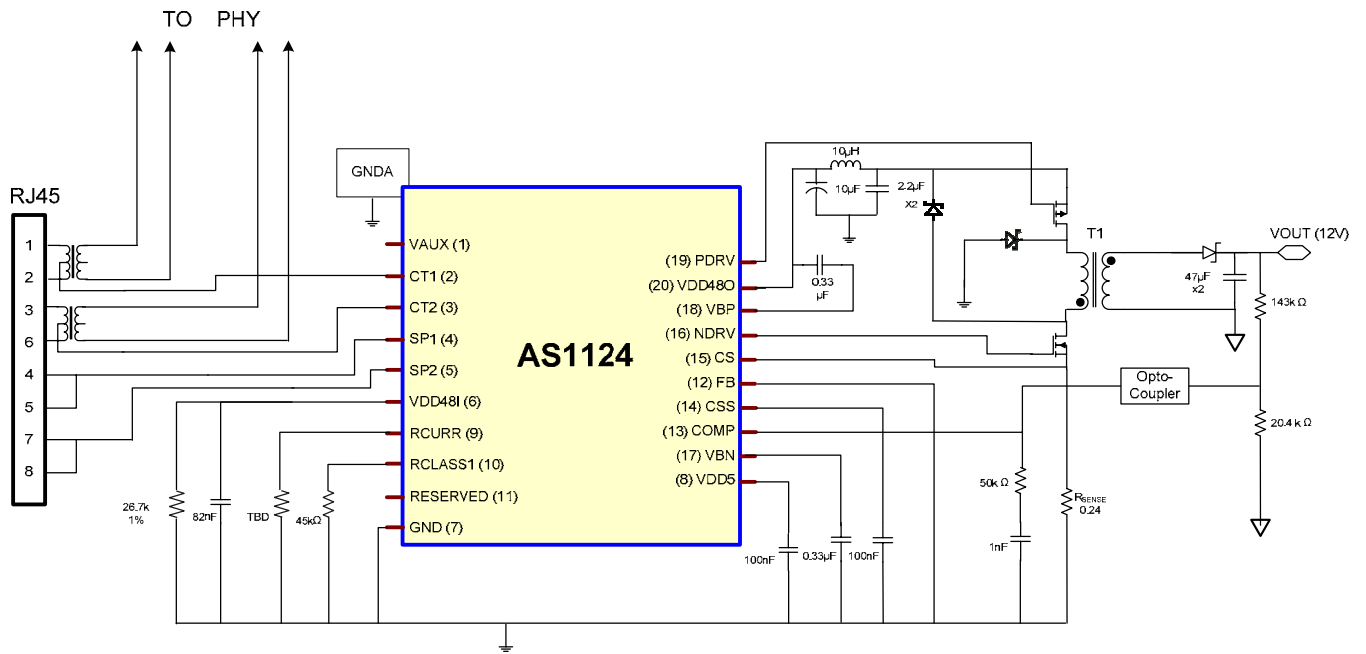

Figure 6. AS1124 PCB Footprint

APPLICATION CIRCUITS

FIGURE 5. 10/100M WITH FLYBACK DC-DC CONVERTER



NOTES.

- All resistors 1% except as otherwise noted.
- Dual FET: Vishay Si7530
- T1: Transtek POET00063
- Primary side Schottky diodes: B1100-13-F or SS1H10
- Secondary side Schottky diodes: MBR3203T3
- Opto-coupler: FOD2712
- Remaining components are common resistors and capacitors.
- 1nF capacitor on CS must be as close to the AS1124 as possible in layout.

FIGURE 6. 10/100M WITH FORWARD DC-DC CONVERTER

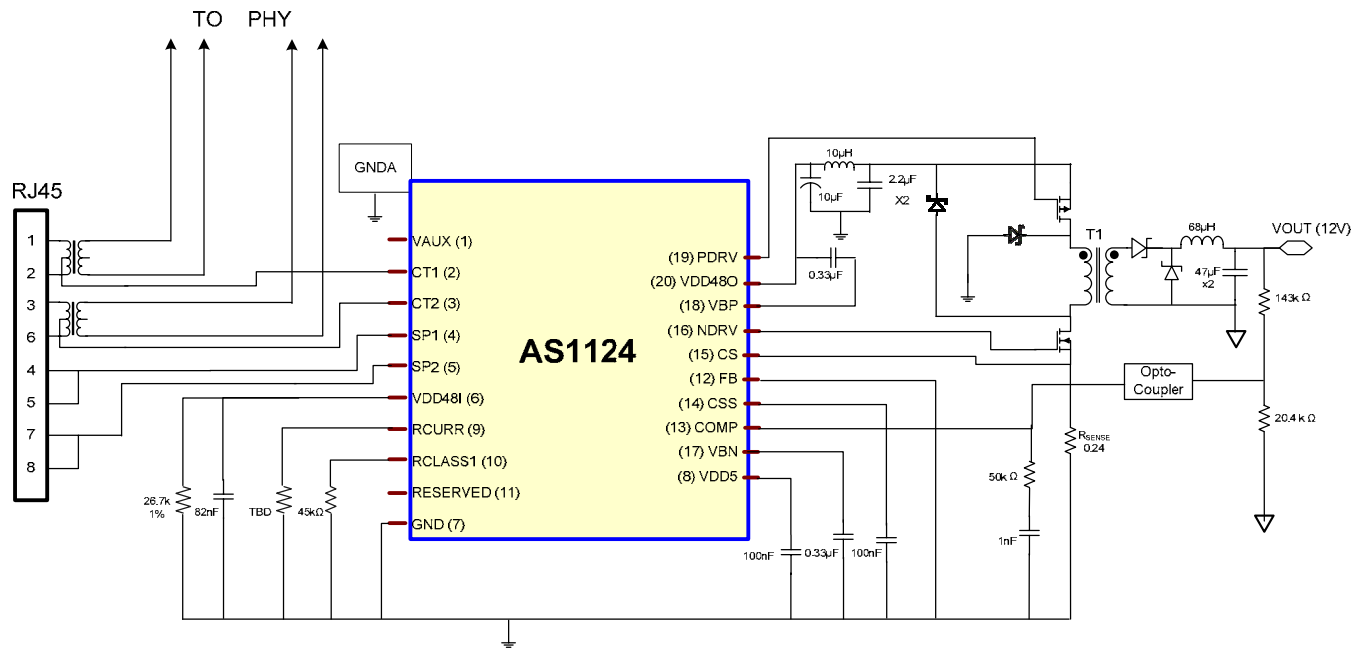

Notes:

All resistors 1% except as otherwise noted.

Dual FET: Vishay Si7530

T1: Transtek POET00062

Primary side Schottky diodes: B1100-13-F or SS1H10

Secondary side Schottky diodes: MBR3203T3

Opto-coupler: FOD2712

Remaining components are common resistors and capacitors.

1nF capacitor on CS pin must be as close to the AS1124 as possible in layout.

FIGURE 7. 10/100M WITH BUCK DC-DC CONVERTER

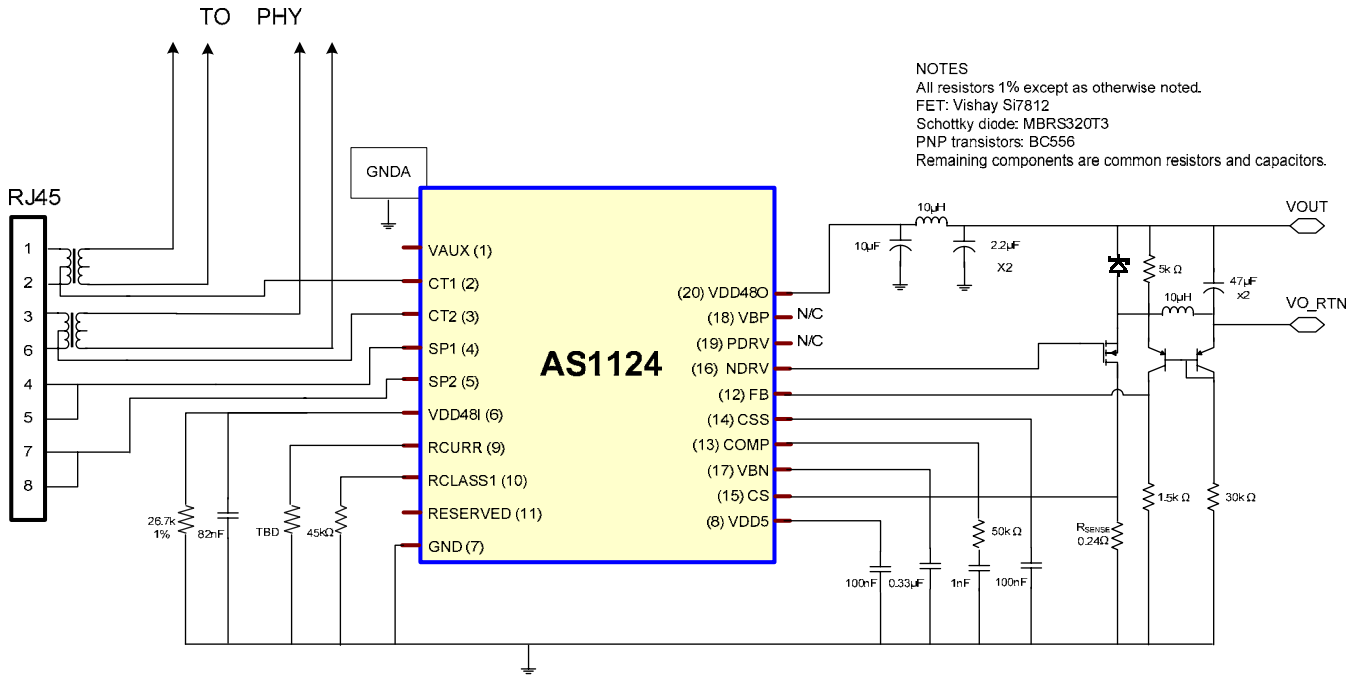

Notes:

All resistors 1% except as otherwise noted.

FET: Vishay Si7812

Schottky diode: MBR320T3

PNP transistors: BC556

Remaining components are common resistors and capacitors.

1nF capacitor on CS pin must be as close to the AS1124 as possible in layout.

FIGURE 8. ALTERNATIVE HOOKUP FOR GE APPLICATIONS

For GE applications, only the inputs change. There are two additional inputs, using RJ45 pins 4/5 and 7/8. Transformer center taps connect with the SP1 and SP2 power inputs.

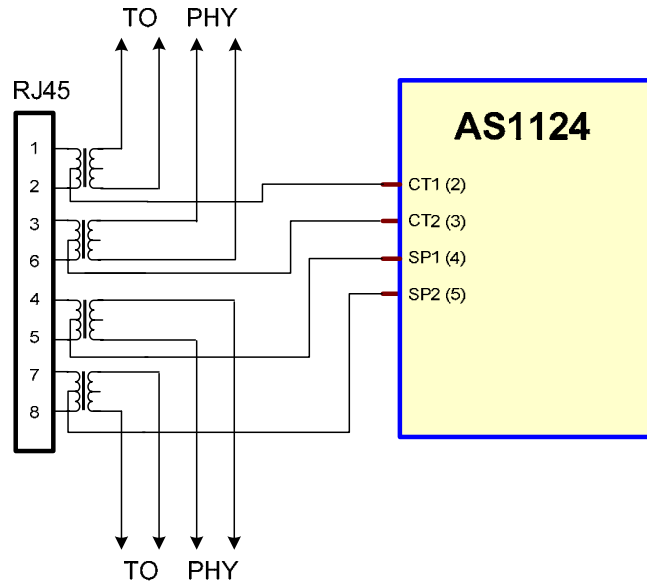

PHYSICAL DIMENSIONS

20 Pin QFN Package, 5mm X 5mm

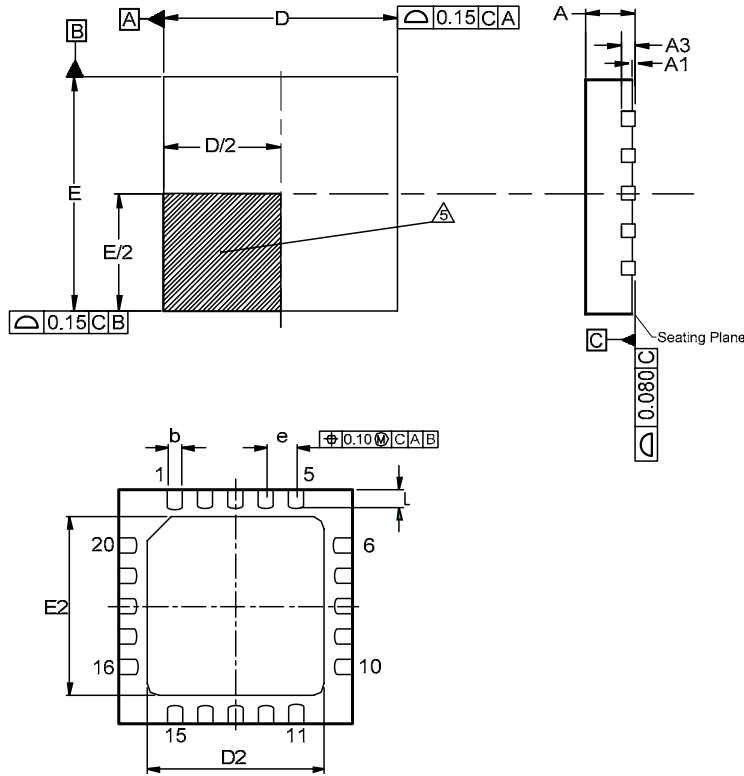

Common Dimensions			
	MIN.	NOM.	MAX
A	0.80	0.85	0.95
A1	0.00	0.02	0.04
A3	0.20 REF.		
D	4.85	5.00	5.15
D2	3.70	3.80	3.90
E	4.85	5.00	5.15
E2	3.70	3.80	3.90
L	0.35	0.40	0.45
N	20L		
b	0.25	0.30	0.35
e	0.650 BSC		
JEDEC	MO-220-VHHC-2		

NOTES

1. Controlling dimensions in mm.
2. Dimension tolerances are  $\pm 0.1$  (angular tolerance  $\pm 3^\circ$ ) unless otherwise specified.
3. All dimensions and tolerances conform to ANSI Y14.5M-1994.
4. Coplanarity applies to exposed pad as well as the terminals.
- △ Pin 1 location may be identified by either a mold or marked feature.
6. JEDEC reference MO-220.

NOTES

**CONTACT INFORMATION**

Akros Silicon Inc.

275 Turn Pike Drive

Folsom, CA. 95630

USA

Tel: (916) 351-8100

Fax: (916) 351-8102

Email inquiries: [marcom@akrossilicon.com](mailto:marcom@akrossilicon.com)

Website: [www.akrossilicon.com](http://www.akrossilicon.com)

---

**IMPORTANT NOTICES****LEGAL NOTICE**

Copyright © 2007 Akros Silicon™. All rights reserved.

Other names, brands and trademarks are the property of others.

Akros Silicon™ assumes no responsibility or liability for information contained in this document. Akros reserves the right to make corrections, modifications, enhancements, improvements, and other changes to its products and services at any time and to discontinue any product or services without notice. The information contained herein is believed to be accurate and reliable at the time of printing.

**LIFE AND SAFETY POLICY**

Akros' products are not authorized for use as critical components in life support systems for surgical implant into the body, or other applications intended to support or sustain life or any other applications whereby a failure of the Akros product could create a situation where personal injury, death or damage to persons, systems, data or business may occur.