

TOSHIBA BiCD Integrated Circuit Silicon Monolithic

# TB67S580FNG

## BiCD Constant-Current Two-phase Bipolar Stepping Motor Driver IC

### 1. Description

The TB67S580FNG is a two-phase bipolar stepping motor driver IC using a PWM chopper.

Fabricated with the BiCD process, the TB67S580FNG rating is 50 V/1.6 A.

The built-in regulator for IC operation allows the motor to be driven by a single VM power supply.

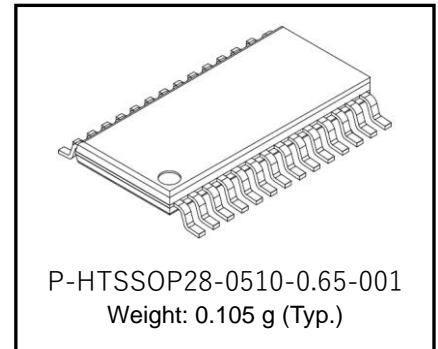

### 2. Features

- BiCD process integrated monolithic IC
- Capable of controlling bipolar stepping motor
- Decay modes select function (Mixed Decay / Slow Decay / Fast Decay)
- Power save function (Sleep mode)
- Clock input control
- 3.3 V regulator output
- Allows full, half, quarter, 1 / 8, 1 / 16, 1 / 32 step operation
- BiCD structure: DMOSFET is used for output power transistor.
- High breakdown voltage and large current: 50 V / 1.6 A (absolute maximum ratings)
- Built-in thermal shutdown detection (TSD), Over current detection (ISD), and Under voltage lockout detection (UVLO)
- Error detection flag output function (nFAULT)
- Decreasing number of external components by reducing charge pump
- Package: P-HTSSOP28-0510-0.65-001

Start of commercial production  
2023-03

## 3. Pin Assignment

TB67S580FNG

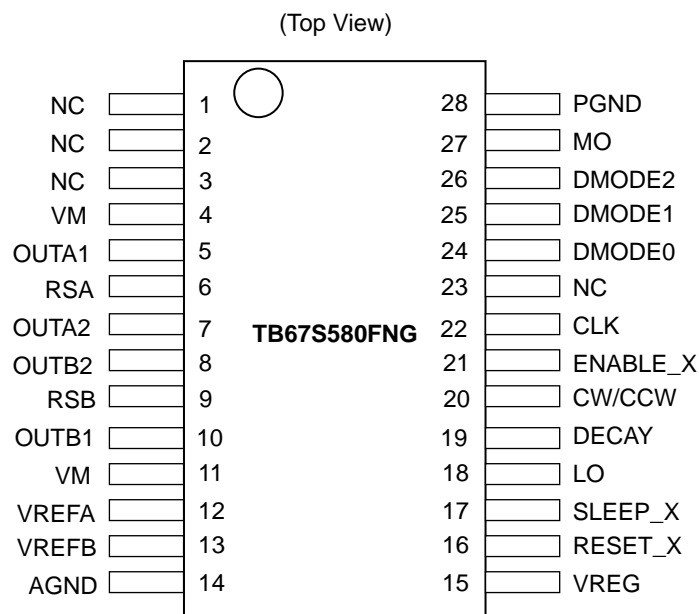
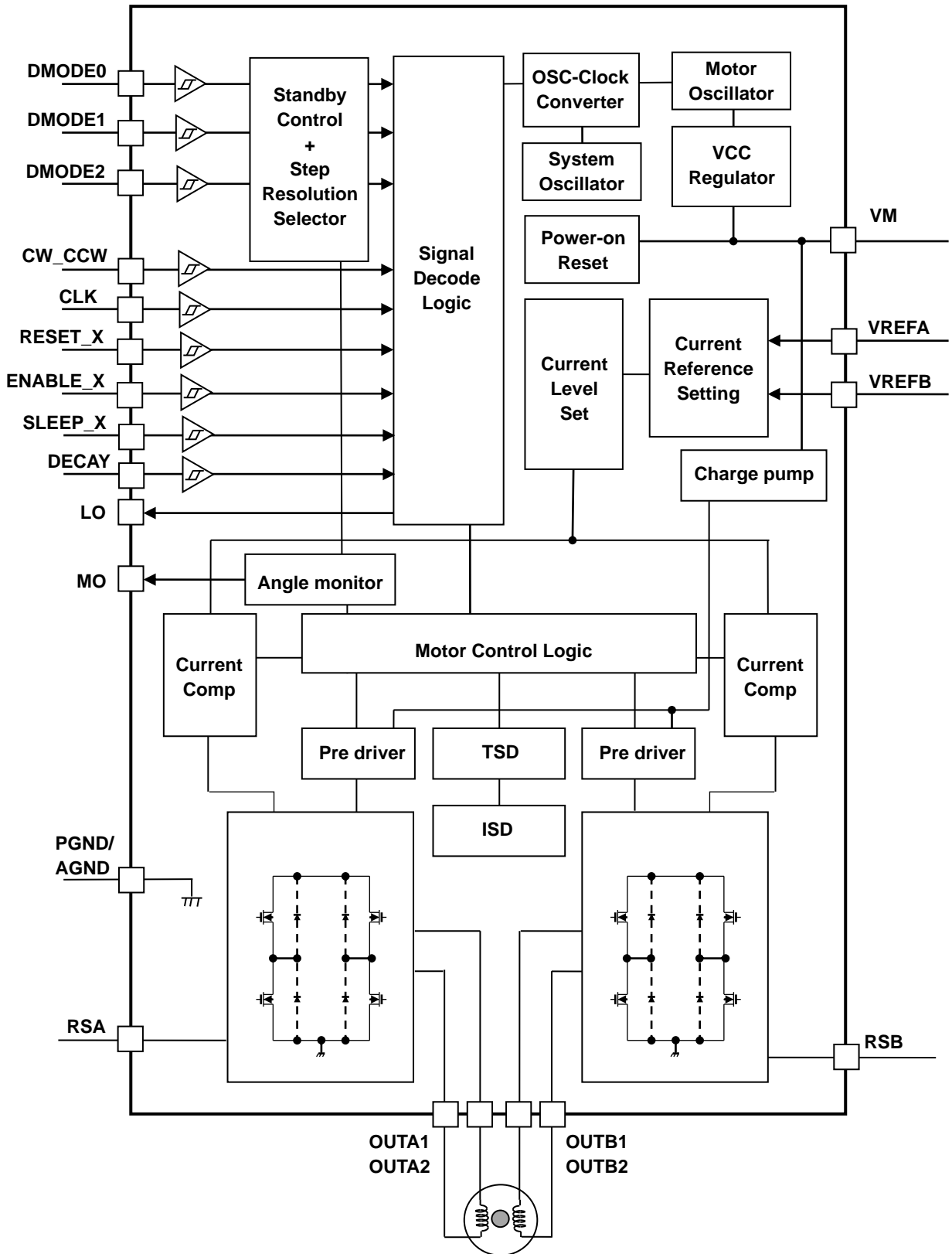

Figure 3 Pin Assignment

**4. Block diagram (TB67S580)**



**Figure 4 Block diagram**

Note: Some of the functional blocks, circuits, or constants in the block diagram may be omitted or simplified for explanatory purpose.

Note: All the grounding wires should be solid patterns and be externally terminated at only one point. Also, a grounding method should be considered for efficient heat dissipation. Careful attention should be paid to the layout of the output, VM and GND traces, to avoid short circuits across output pins or to the power supply or ground. If such a short circuit occurs, the device may be permanently damaged. Also, the utmost care should be taken for pattern designing and implementation of the device since it has power supply pins (VM, OUTA1, OUTA2, OUTB1, OUTB2, PGND and AGND) through which a particularly large current may run. If these pins are wired incorrectly, an operation error may occur or the device may be destroyed. The logic input pins must also be wired correctly. Otherwise, the device may be damaged owing to a current running through the IC that is larger than the specified current. Careful attention should be paid to design patterns and mounting.

## 5. Pin Description

TB67S580FNG

**Table 5 Pin Description**

Pin No.	Pin Name	Function
1	NC	Non-connection pin
2	NC	Non-connection pin
3	NC	Non-connection pin
4	VM	Motor power supply pin (HSW_Ach)
5	OUTA1	H-bridge Ach output + pin
6	RSA	H-bridge Ach current sense resistor connection pin
7	OUTA2	H-bridge Ach output - pin
8	OUTB2	H-bridge Bch output - pin
9	RSB	H-bridge Bch current sense resistor connection pin
10	OUTB1	H-bridge Bch output + pin
11	VM	Motor power supply pin (HSW_Bch)
12	VREFA	Current set reference input pin for H-bridge Ach
13	VREFB	Current set reference input pin for H-bridge Bch
14	AGND	Ground pin
15	VREG	3.3V regulator voltage output pin
16	RESET_X	Reset input pin
17	SLEEP_X	Sleep mode input pin
18	LO	Error detection flag output pin
19	DECAY	Decay mode select pin
20	CW_CCW	CW/CCW (rotation direction) set pin
21	ENABLE_X	Enable (H-bridge output ON/OFF) input pin
22	CLK	Step clock input pin
23	NC	Non-connection pin
24	DMODE0	Step mode select pin
25	DMODE1	Step mode select pin
26	DMODE2	Step mode select pin
27	MO	Electrical angle monitor pin
28	PGND	Ground pin

Note: Please do not run patterns under NC pins.

## 6. Input / Output Equivalent Circuit

**Table 6 Input / Output Equivalent Circuit**

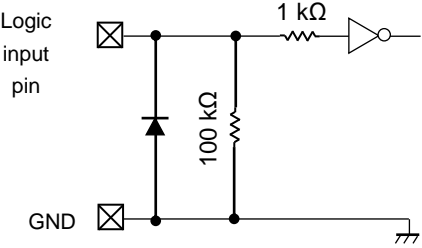
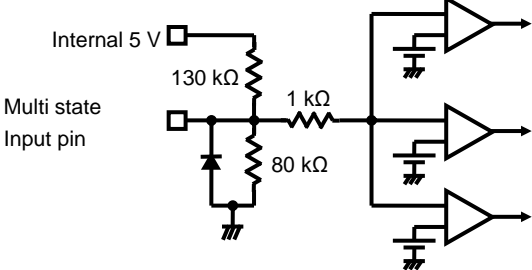
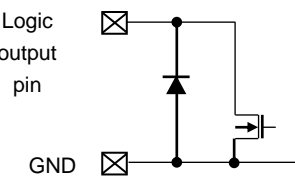
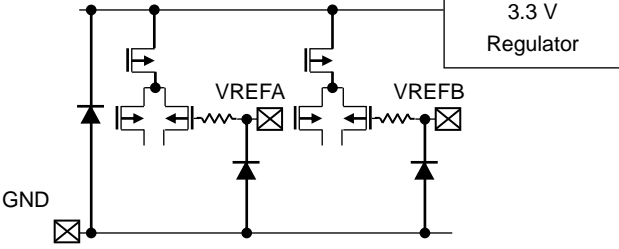
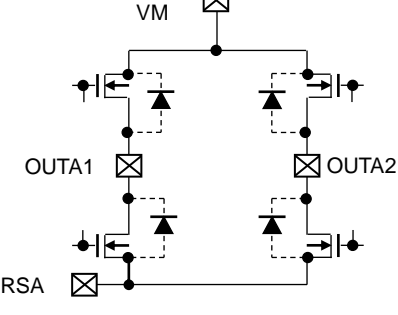
Pin name	Equivalent circuit
CLK ENABLE_X RESET_X CW_CCW DMODE0 DMODE1 DMODE2	 <p>Logic input pin</p> <p>GND</p>
DECAV	 <p>Internal 5 V</p> <p>Multi state Input pin</p>
MO LO	 <p>Logic output pin</p> <p>GND</p>
VREFA VREFB	 <p>3.3 V Regulator</p> <p>GND</p>
VM VM OUTA1 OUTA2 OUTB1 OUTB2 RSA RSB	 <p>VM</p> <p>OUTA1</p> <p>OUTA2</p> <p>OUTB1</p> <p>OUTB2</p> <p>RSA</p> <p>RSB</p> <p>* OUTB1, OUTB2: Same</p>

Note: The equivalent circuit diagrams may be simplified for explanatory purposes.

## 7. Operation Description: TB67S580FNG

### 7.1. SLEEP\_X Function

The operation can resume from the forced off mode, which is configured by the thermal shutdown detection (TSD) and the over current detection (ISD), by setting sleep mode once and then setting the normal operation mode again. The operation mode returns after 10 ms from nSLEEP=High input.

**Table 7.1 SLEEP\_X Function**

SLEEP_X	Function
L	Low-power sleep mode (Charge pump is stopped, the 3.3 V regulator is disabled.)
H	Normal operation

### 7.2. CLK Function

Each up-edge of the CLK signal shifts the current step and electrical angle of the motor.

**Table 7.2 CLK Function**

CLK	Function
↑	Shifts the electrical angle and current step per each up-edge.
↓	— (no change, maintain former state)

### 7.3. ENABLE\_X Function

The ENABLE\_X pin controls the ON and OFF of the stepping motor outputs. Motor operation starts by switching ON. All of the MOSFETs turn off and become high impedance (hereafter, Hi-Z) by switching OFF.

**Table 7.3 ENABLE\_X Function**

ENABLE_X	Function
L	MOSFET outputs: ON (Normal operation)
H	MOSFET outputs: OFF (Hi-Z)

### 7.4. CW\_CCW Function

The CW/CCW pin controls the rotation direction of the stepping motor.

**Table 7.4 CW\_CCW Function**

CW_CCW	Function
L	Counter clockwise operation (CCW)
H	Clockwise operation (CW)

## 7.5. DMODE0, DMODE1, DMODE2 Function

The DMODE0-2 pins are used to set the step resolution for stepping motor operation. If the step resolution mode is changed during motor operating, the step current will shift to the current of the nearest electric angle for the new DMODE0-2 setting at the rising edge of CLK.

**Table 7.5 DMODE0 , DMODE1 , DMODE2 Function**

DMODE2	DMODE1	DMODE0	Function
L	L	L	Full step (2-phase excitation) with 71 % current
L	L	H	Half step resolution (1-2-phase excitation)
L	H	L	Quarter step resolution (W1-2-phase excitation)
L	H	H	1 / 8 step resolution (2W1-2-phase excitation)
H	L	L	1 / 16 step resolution (4W1-2-phase excitation)
H	L	H	1 / 32 step resolution (8W1-2-phase excitation)
H	H	L	1 / 32 step resolution (8W1-2-phase excitation)
H	H	H	1 / 32 step resolution (8W1-2-phase excitation)

## 7.6. RESET\_X Function

The RESET\_X pin initializes the internal electrical angle. All internal logic circuits are reset.

**Table 7.6.1 RESET\_X Function**

RESET_X	Function
L	Initializes the internal electrical angle
H	Normal operation

When the RESET\_X pin is set to Low, the current setting for each H-bridge (Ach and Bch) will be set to the value below.

**Table 7.6.2 Initial at RESET**

Step resolution	Ach current	Bch current	Electrical angle
Full step	71 %	71 %	45 °
Half step resolution (1-2-phase excitation)	71 %	71 %	45 °
Quarter step resolution (W1-2-phase excitation)	71 %	71 %	45 °
1/8 step resolution (2W1-2-phase excitation)	71 %	71 %	45 °
1/16 step resolution (4W1-2-phase excitation)	71 %	71 %	45 °
1/32 step resolution (8W1-2-phase excitation)	71 %	71 %	45 °



## 7.7. MO Function

The MO pin confirms the internal electrical angles.

**Table 7.7 MO Function**

MO	Function
H (at pull-up)	Electrical angle is not at the initial position
L	Electrical angle is at the initial position

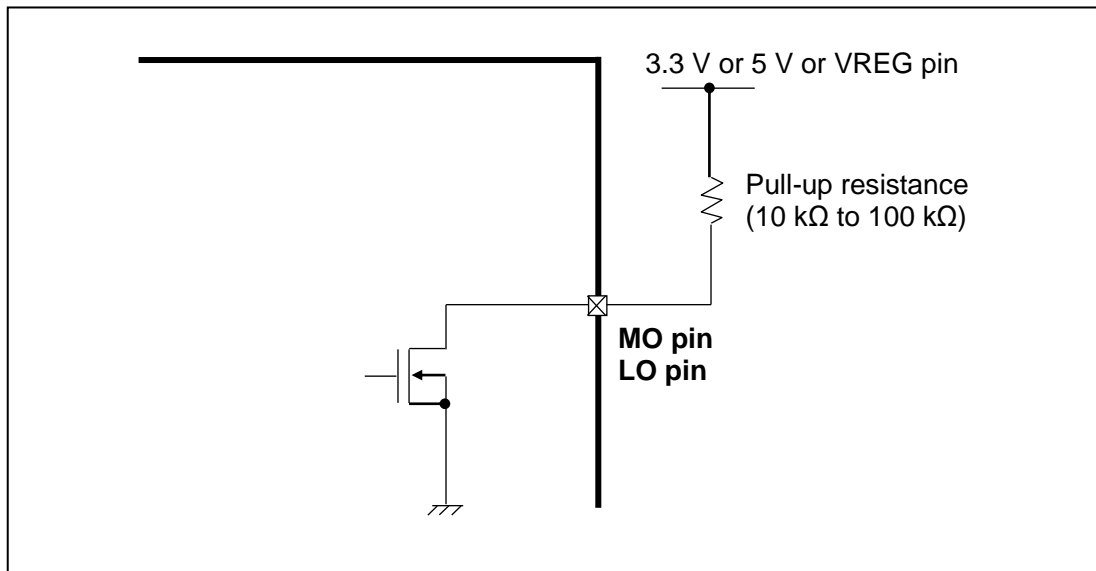

**Figure7.7 MO, LO pin equivalent circuit diagram**

Note: The equivalent circuit diagrams may be simplified for explanatory purposes.

## 7.8. Sequence in each Drive Mode

[Full step resolution]

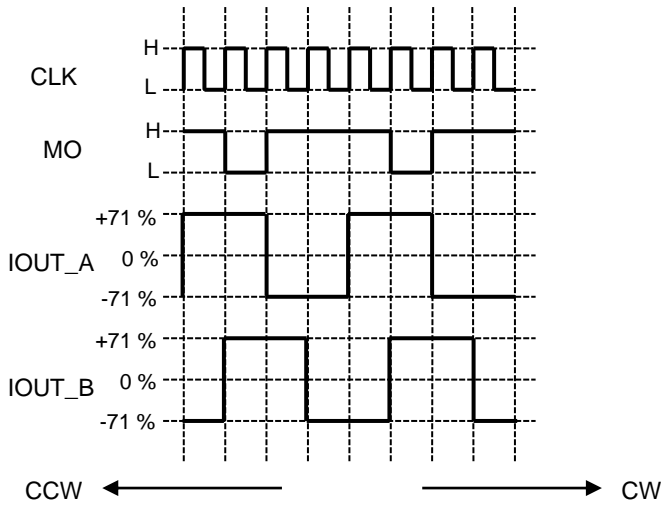

Figure7.8.1 Full step resolution

[Half step resolution]

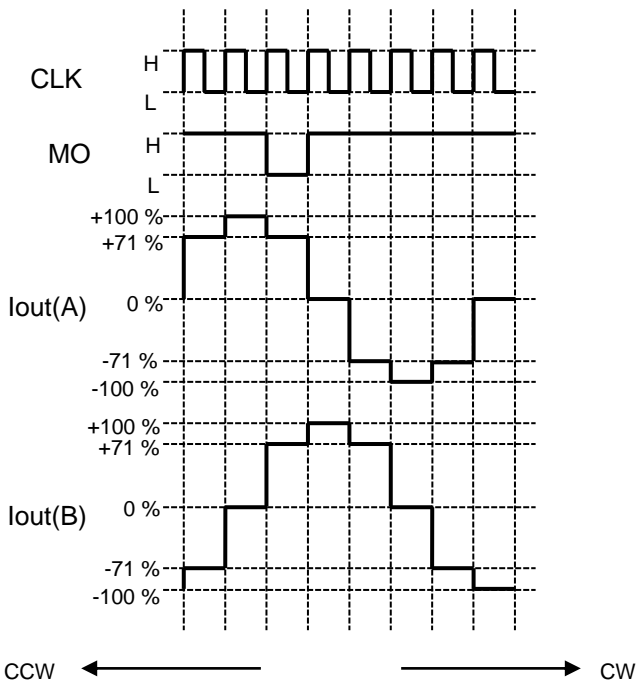
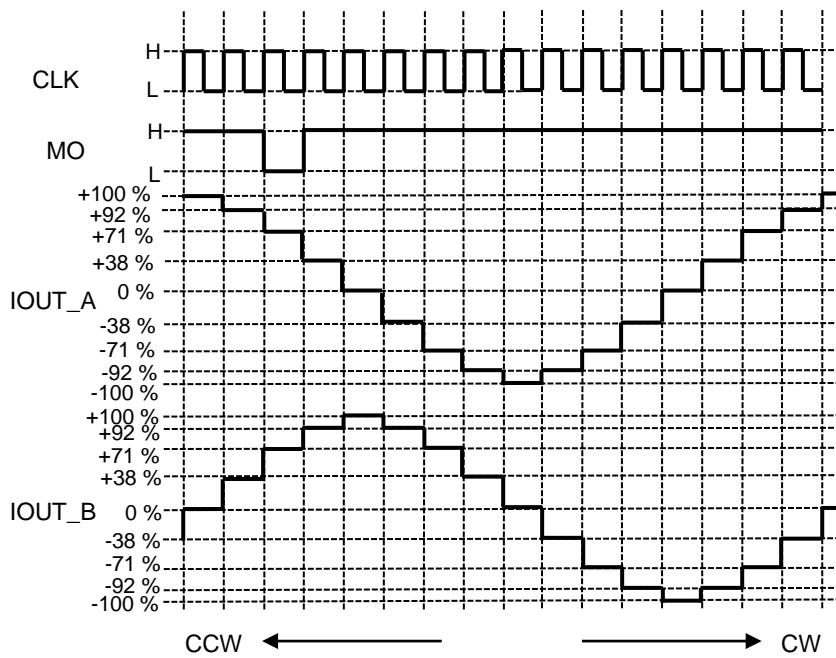

Figure7.8.2 Half step resolution

[Quarter step resolution]



**Figure7.8.3 Quarter step resolution**

Note: Waveform of MO output: State of pull-up.

Note: Timing charts may be simplified for explanatory purpose.

## 7.9. Step resolution and set current

The step current for each resolution is shown in the table below. (In case of CW\_CCW = High)

**Table 7.9 Step resolution and set current**

STEP	1 / 32		1 / 16		1 / 8		1 / 4		1 / 2		Full	
	Ach (%)	Bch (%)	Ach (%)	Bch (%)	Ach (%)	Bch (%)	Ach (%)	Bch (%)	Ach (%)	Bch (%)	Ach (%)	Bch (%)
00	100	0	100	0	100	0	100	0	100	0		
01	100	5										
02	100	10	100	10								
03	99	15										
04	98	20	98	20	98	20						
05	97	24										
06	96	29	96	29								
07	94	34										
08	92	38	92	38	92	38	92	38				
09	90	43										
010	88	47	88	47								
011	86	51										
012	83	56	83	56	83	56						
013	80	60										
014	77	63	77	63								
015	74	67										
016	71	71	71	71	71	71	71	71	71	71	71	71
017	67	74										
018	63	77	63	77								
019	60	80										
020	56	83	56	83	56	83						
021	51	86										
022	47	88	47	88								
023	43	90										
024	38	92	38	92	38	92	38	92				
025	34	94										
026	29	96	29	96								
027	24	97										
028	20	98	20	98	20	98						
029	15	99										
030	10	100	10	100								
031	5	100										
032	0	100	0	100	0	100	0	100	0	100		
033	-5	100										
034	-10	100	-10	100								
035	-15	99										
036	-20	98	-20	98	-20	98						
037	-24	97										
038	-29	96	-29	96								
039	-34	94										
040	-38	92	-38	92	-38	92	-38	92				
041	-43	90										
042	-47	88	-47	88								

STEP	1 / 32		1 / 16		1 / 8		1 / 4		1 / 2		Full	
	Ach (%)	Bch (%)	Ach (%)	Bch (%)	Ach (%)	Bch (%)	Ach (%)	Bch (%)	Ach (%)	Bch (%)	Ach (%)	Bch (%)
043	-51	86										
044	-56	83	-56	83	-56	83						
045	-60	80										
046	-63	77	-63	77								
047	-67	74										
048	-71	71	-71	71	-71	71	-71	71	-71	71	-71	71
049	-74	67										
050	-77	63	-77	63								
051	-80	60										
052	-83	56	-83	56	-83	56						
053	-86	51										
054	-88	47	-88	47								
055	-90	43										
056	-92	38	-92	38	-92	38	-92	38				
057	-94	34										
058	-96	29	-96	29								
059	-97	24										
060	-98	20	-98	20	-98	20						
061	-99	15										
062	-100	10	-100	10								
063	-100	5										
064	-100	0	-100	0	-100	0	-100	0	-100	0		
065	-100	-5										
066	-100	-10	-100	-10								
067	-99	-15										
068	-98	-20	-98	-20	-98	-20						
069	-97	-24										
070	-96	-29	-96	-29								
071	-94	-34										
072	-92	-38	-92	-38	-92	-38	-92	-38				
073	-90	-43										
074	-88	-47	-88	-47								
075	-86	-51										
076	-83	-56	-83	-56	-83	-56						
077	-80	-60										
078	-77	-63	-77	-63								
079	-74	-67										
080	-71	-71	-71	-71	-71	-71	-71	-71	-71	-71	-71	-71
081	-67	-74										
082	-63	-77	-63	-77								
083	-60	-80										
084	-56	-83	-56	-83	-56	-83						
085	-51	-86										
086	-47	-88	-47	-88								
087	-43	-90										
088	-38	-92	-38	-92	-38	-92	-38	-92				
089	-34	-94										
090	-29	-96	-29	-96								

STEP	1 / 32		1 / 16		1 / 8		1 / 4		1 / 2		Full	
	Ach (%)	Bch (%)	Ach (%)	Bch (%)	Ach (%)	Bch (%)	Ach (%)	Bch (%)	Ach (%)	Bch (%)	Ach (%)	Bch (%)
—												
091	-24	-97										
092	-20	-98	-20	-98	-20	-98						
093	-15	-99										
094	-10	-100	-10	-100								
095	-5	-100										
096	0	-100	0	-100	0	-100	0	-100	0	-100		
097	5	-100										
098	10	-100	10	-100								
099	15	-99										
0100	20	-98	20	-98	20	-98						
0101	24	-97										
0102	29	-96	29	-96								
0103	34	-94										
0104	38	-92	38	-92	38	-92	38	-92				
0105	43	-90										
0106	47	-88	47	-88								
0107	51	-86										
0108	56	-83	56	-83	56	-83						
0109	60	-80										
0110	63	-77	63	-77								
0111	67	-74										
0112	71	-71	71	-71	71	-71	71	-71	71	-71	71	-71
0113	74	-67										
0114	77	-63	77	-63								
0115	80	-60										
0116	83	-56	83	-56	83	-56						
0117	86	-51										
0118	88	-47	88	-47								
0119	90	-43										
0120	92	-38	92	-38	92	-38	92	-38				
0121	94	-34										
0122	96	-29	96	-29								
0123	97	-24										
0124	98	-20	98	-20	98	-20						
0125	99	-15										
0126	100	-10	100	-10								
0127	100	-5										
0128	100	0	100	0	100	0	100	0	100	0		

## 7.10. DECAY mode select Function

The Decay mode in constant current control is selectable by the state of the DECAY pin.

In Mixed decay mode, the IC enters to the Fast decay mode. Then, the IC transmits from Fast decay mode to slow decay mode at a fixed period of time (75 % of PWM cycle). Moreover, after the remainder of the fixed PWM period (25 % of the PWM cycle), the slow decay mode ends. Mixed decay mode occurs only if the output current is decreasing; if the current is increasing, decay operation is forced slow mode.

**Table 7.10 DECAY mode select Function**

DECAY	Function
L	Slow decay mode
H	Fast decay mode
OPEN	Mixed decay mode

## 8. Motor output MOSFET operation mode (Mixed Decay)

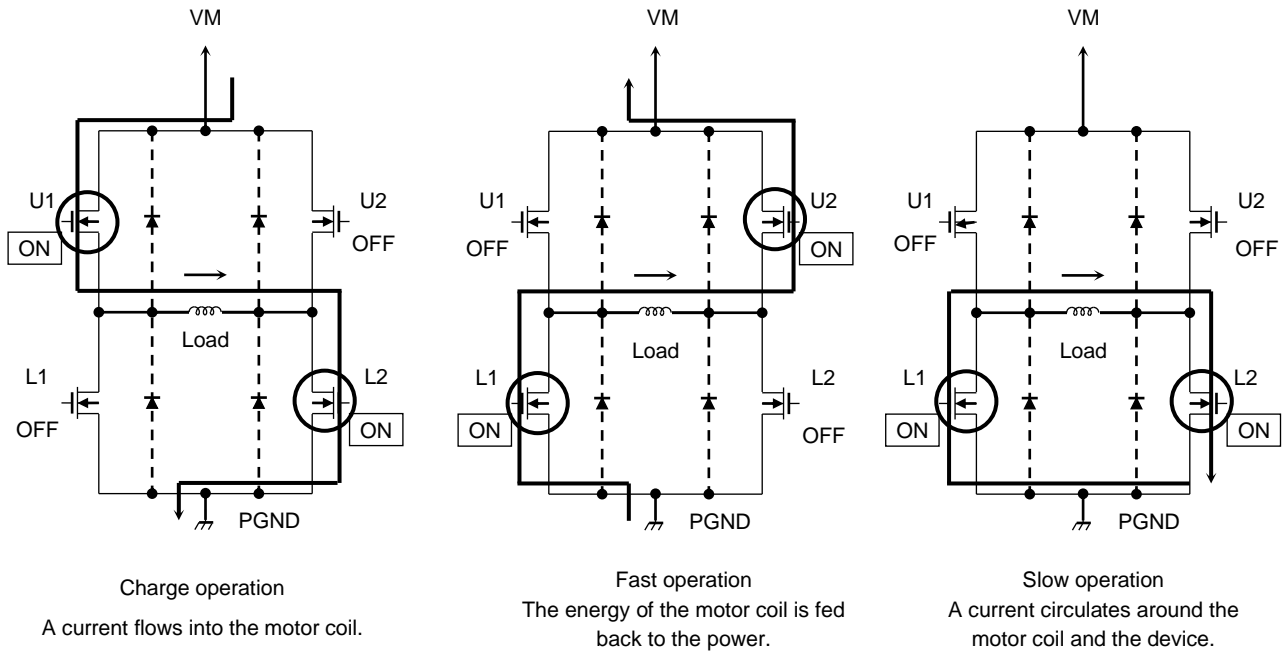

**Figure8 Motor output MOSFET operation mode**

※ In the timing of an output switching, the time to prevent a through current is predefined.

### 8.1. Operation Function of Output Transistor

**Table 8.1.1 At positive current**

Mode	U1	U2	L1	L2
Charge	ON	OFF	OFF	ON
Fast	OFF	ON	ON	OFF
Slow	OFF	OFF	ON	ON

Note: The parameters shown in the table above are examples when the current flows in the directions shown in the figures above. For the current flowing in the reverse direction, the parameters is shown below.

**Table 8.1.2 At negative current**

Mode	U1	U2	L1	L2
Charge	OFF	ON	ON	OFF
Fast	ON	OFF	OFF	ON
Slow	OFF	OFF	ON	ON

This IC controls the motor current to be constant by 3 modes listed above.

The equivalent circuit diagrams may be simplified or some parts of them may be omitted for explanatory purposes.



## 9. Constant current threshold ( $I_{OUT}$ ) calculation

The constant current PWM threshold (Setting current value) can be set via the current-sensing resistor (RRS) and the reference voltage ( $V_{REF}$ ).

The Setting current value:  $I_{OUT}$  can be set, as follows:

$$I_{OUT} = V_{REF} / 5 / RRS$$

Example: When  $V_{REFA} = V_{REFB} = 1.0$  V and  $RSA = RSB = 0.22 \Omega$ ,  $I_{OUT} = 0.91$  A.

## 10. Power consumption of the IC

Power of the IC is consumed by the transistor of the output block and that of the logic block mainly.

### 10.1. Power consumption of the power transistor

Power of the output block is consumed by the upper and lower MOSFET of the H-Bridge.

Power consumption of the upper or lower transistor of the H-Bridge is calculated from below formula.

$$P(\text{out}) = I_{\text{OUT}}(\text{A}) \times V_{\text{DS}}(\text{V}) = I_{\text{OUT}}(\text{A})^2 \times R_{\text{ON}}(\Omega) \dots \dots \dots (1)$$

When the current waveform of the motor output corresponds to the ideal square waveform in the full-step resolution, average power of output block can be provided as follows

When  $R_{\text{ON}} = 0.45 \Omega$ ,  $I_{\text{OUT}}(\text{peak: Max}) = 1.0 \text{ A}$ , and  $V_{\text{M}} = 24 \text{ V}$ ,

$$P(\text{out}) = 2(\text{Tr}) \times 1.0(\text{A})^2 \times 0.4(\Omega) \dots \dots \dots (2)$$

$$= 0.8(\text{W})$$

### 10.2. Power consumption of logic and I<sub>M</sub> systems

Power consumptions of logic and I<sub>M</sub> systems are calculated by separating the states (operating and standby).

$$I(I_{\text{M}2}) = 5 \text{ mA (Typ.)} \quad : \text{ Operating/axis}$$

$$I(I_{\text{M}1}) = 10 \mu\text{A (Typ.)} \quad : \text{ Standby/axis}$$

Output system is connected to V<sub>M</sub> (24 V). (Output system: Current consumed by the circuit connected to V<sub>M</sub> + Current consumed by switching output steps)

Power consumption is calculated as follows;

$$P(I_{\text{M}2}) = 24(\text{V}) \times 0.005(\text{A}) \dots \dots \dots (3)$$

$$= 0.12(\text{W})$$

### 10.3. Power consumption

Total power consumption P (total) is calculated from the results of '1' and '2' above.

$$P(\text{total}) = P(\text{out}) + P(I_{\text{M}2}) = 0.92(\text{W})$$

Power consumption of 1 axle in standby mode is as follows;

$$P(\text{Standby mode}) = 24(\text{V}) \times 0.00001(\text{A}) = 0.00024(\text{W})$$

About the heat design of the board etc., please evaluate it by the actual board enough, and configure the appropriate margin.

### 11. Thermal shutdown detection (Auto return type)

This function turns off the IC operation temporarily when the over heat of the device is detected. It has a dead band time to avoid error detection occurred by the external noise. When over heat is detected, all channels are turned off. Since the temperature has a hysteresis range, when the junction temperature falls to the return temperature, the operation returns automatically to the normal operation.

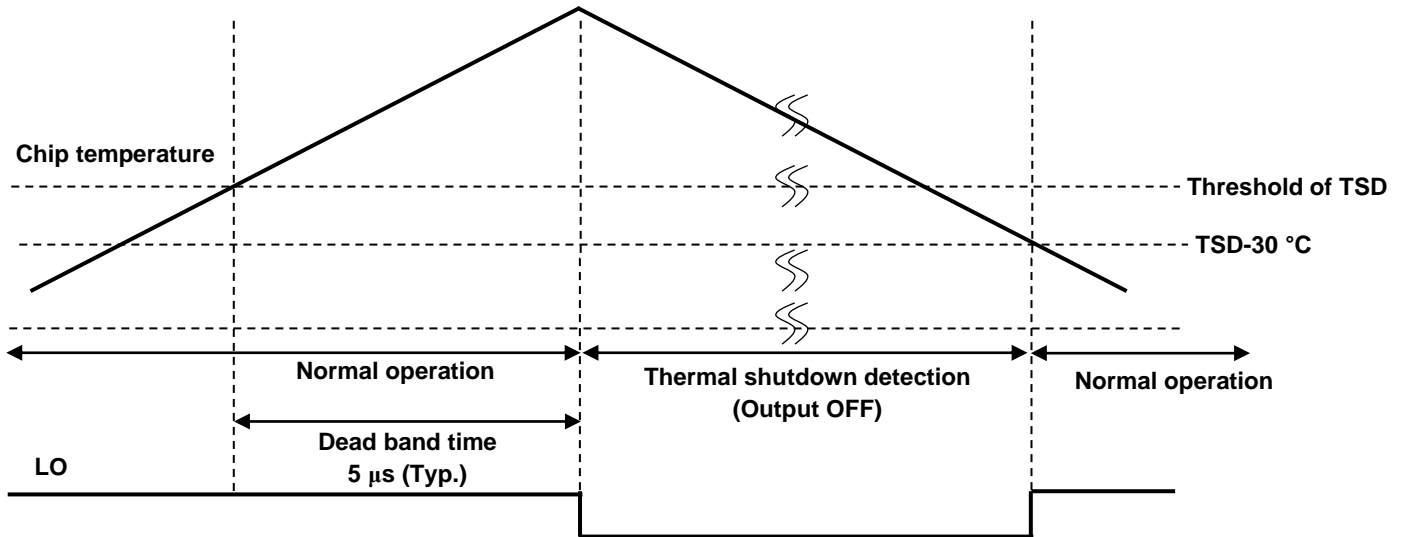

Figure11.1 Thermal shutdown detection timing chart 1

Timing charts may be simplified for explanatory purposes. The value in the timing chart is the reference value.

TSD function has a detection deadband time. When operating near the TSD detection threshold temperature, when the temperature of the IC falls below the TSD detection threshold immediately after the dead band time ends, normal operation is immediately performed and the LO signal is output momentarily (156 to 312 ns (Typ.)).

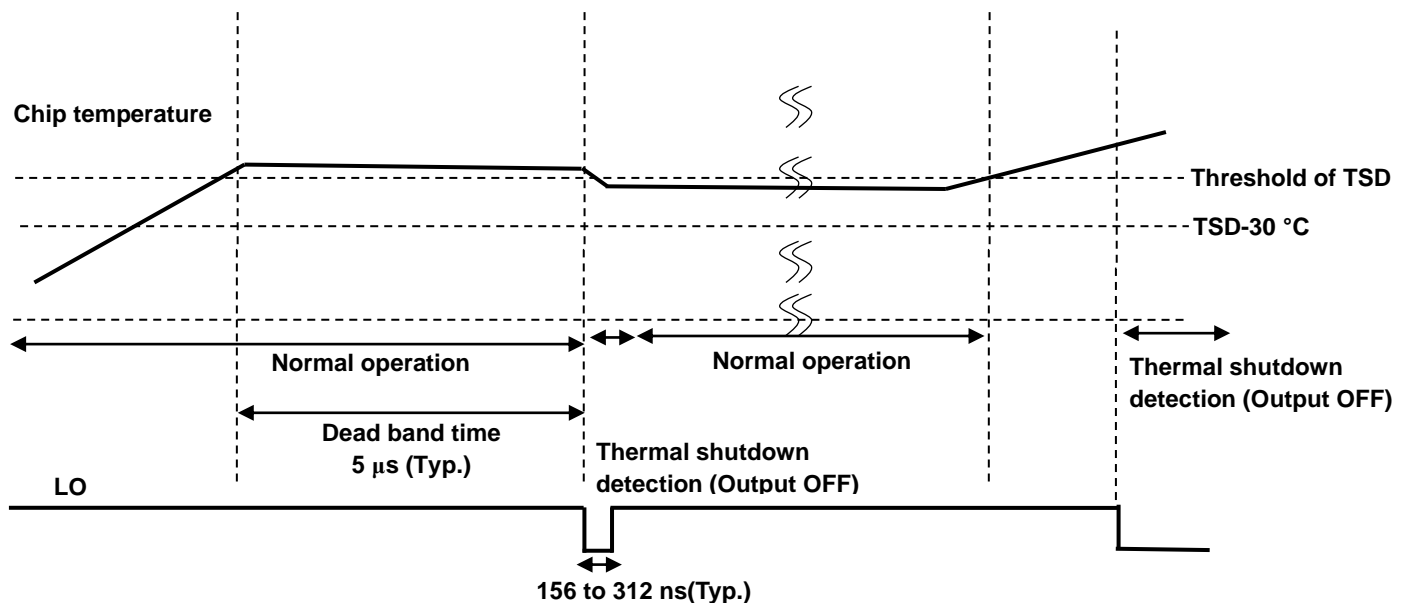

Figure11.2 Thermal shutdown detection timing chart 2

Timing charts may be simplified for explanatory purposes. The value in the timing chart is the reference value.

## 12. Over current detection (Latch type: Operation state before detection is maintained.)

This function turns off the IC operation temporarily when the short-circuiting between outputs and the short-circuiting to the power supply or ground occur. It has a dead band time to avoid error detection occurred by the spike current which generates in switching and the external noise. When over current is detected, not only the corresponding channels but both channels are turned off.

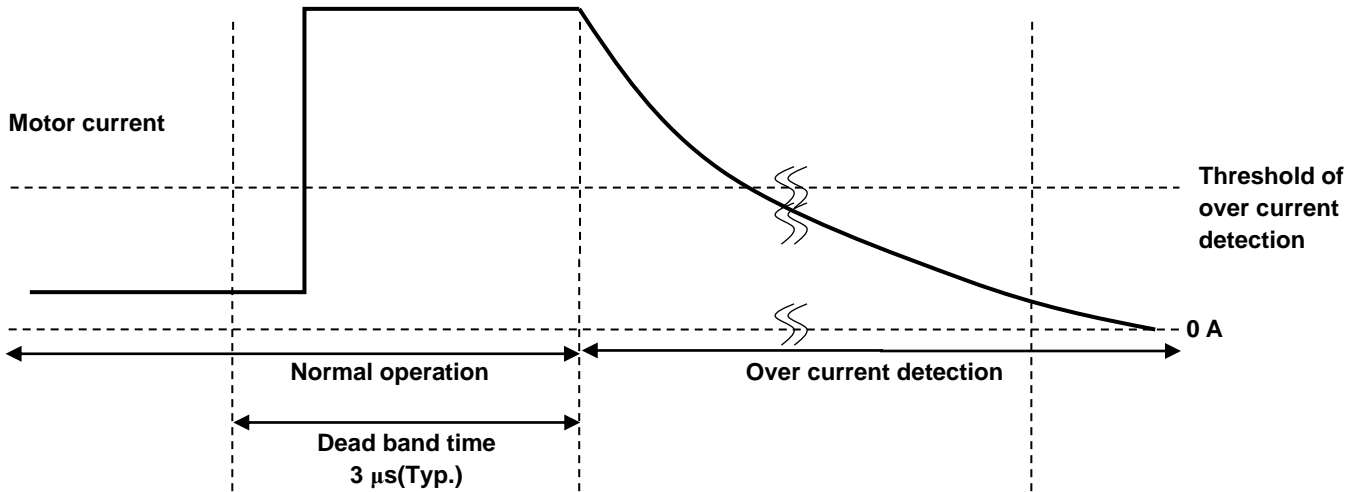

Figure12 Over current detection timing chart

Timing charts may be simplified for explanatory purposes. The value in the timing chart is the reference value.

### 13. Absolute Maximum Ratings ( $T_a = 25\text{ }^\circ\text{C}$ )

**Table 13 Absolute Maximum Ratings**

Characteristics	Symbol	Rating	Unit
Motor output voltage	$V_{OUT}$	50	V
Motor power supply	$V_M$	45	V
Motor output current (Note1)	$I_{OUT}$	1.6	A
Logic input voltage	$V_{IN}$	6.0	V
Vref reference voltage	$V_{ref}$	6.0	V
Monitor voltage for electrical angle	$V_{MO}$	6.0	V
Power dissipation (Note2)	$P_D$	4.0	W
Operating temperature	$T_{opr}$	-40 to 85	$^\circ\text{C}$
Storage temperature	$T_{stg}$	-55 to 150	$^\circ\text{C}$
Junction temperature	$T_{j(MAX)}$	150	$^\circ\text{C}$

Note1: The maximum current value in normal operation should be kept 1.28 A or less per phase after calculating heat generation. The maximum output current may be further limited in view of the thermal considerations, depending on the ambient temperature and board conditions.

Note2: Based on JEDEC standard 4-layer PCB ( $T_a = 25\text{ }^\circ\text{C}$ )

When  $T_a$  exceeds  $25\text{ }^\circ\text{C}$ , derating with  $32\text{ mW}/^\circ\text{C}$  is necessary.

$T_a$  : Ambient temperature of the IC

$T_{opr}$  : Ambient temperature while the IC is active.

$T_j$  : Junction temperature while the IC is active. The maximum junction temperature is limited by the thermal shutdown circuit (TSD).

It is advisable to keep the maximum current below a certain level so that the maximum junction temperature,  $T_{j(MAX)}$ , will not exceed  $120\text{ }^\circ\text{C}$ .

#### Absolute maximum ratings

The absolute maximum ratings of a semiconductor device are a set of ratings that must not be exceeded, even for a moment. Do not exceed any of these ratings.

Exceeding the rating (s) may cause device breakdown, damage or deterioration, and may result in injury by explosion or combustion. The value of even one parameter of the absolute maximum ratings should not be exceeded under any circumstances. The TB67S580FNG does not have overvoltage detection circuit. Therefore, the device is damaged if a voltage exceeding its rated maximum is applied.

All voltage ratings, including supply voltages, must always be followed. The other notes and considerations described later should also be referred to.

### 14. Operating Range ( $T_a = -40\text{ to }85\text{ }^\circ\text{C}$ )

**Table 14 Operating Range**

Characteristics	Symbol	Min	Typ.	Max	Unit	Remarks
Motor power supply (Note1)	$V_M$	8.2	24.0	44	V	—
Motor output current	$I_{OUT}$	—	—	1.28	A	Per phase (Note1)
Logic input voltage	$V_{IN(H)}$	2.2	—	5.25	V	Logic input High Level
	$V_{IN(L)}$	0	—	0.7	V	Logic input Low Level
Chopping frequency	$f_{CHOP}$	—	50	—	kHz	—
Clock frequency	$f_{CLK}$	—	—	250	kHz	—
Vref reference voltage	$V_{REF}$	1	—	3.6	V	—
VRS detection voltage	$V_{RS}$	0.9	1.0	1.1	V	—

Note1: The actual maximum current may be limited by the operating environment (operating conditions such as exciting mode and operating time, or by the surrounding temperature or board heat dissipation). Determine a realistic maximum current by calculating the heat generated under the operating environment.

## 15. Electrical Specifications

### 15.1. Electrical Specifications 1 ( $T_a = 25\text{ }^\circ\text{C}$ , $V_M = 24\text{ V}$ unless otherwise specified)

Table 15.1 Electrical Specifications 1

Characteristics		Symbol	Test condition	Min	Typ.	Max	Unit
Logic input voltage	High	$V_{IN(H)}$	Logic input pin (Note)	2.2	—	5.25	V
	Low	$V_{IN(L)}$	Logic input pin (Note)	0	—	0.7	V
Logic input hysteresis voltage		$V_{IN(HYS)}$	Logic input pin (Note)	100	200	300	mV
Logic input current	High	$I_{IN(H)}$	Logic input voltage: 3.3 V	—	—	100	$\mu\text{A}$
	Low	$I_{IN(L)}$	Logic input voltage: 0 V	-20	—	20	$\mu\text{A}$
MO output pin voltage		$V_{OL(MO)}$	$I_{OL}=5\text{ mA}$ , Output: Low	—	0.2	0.5	V
Power consumption		$I_{M1}$	Output pin: Open, Sleep mode	—	10	20	$\mu\text{A}$
		$I_{M2}$	Output pin: Open, Operating mode	—	5	8	mA
Output leakage current	High-side	$I_{OH}$	$V_M = 44\text{ V}$ , $V_{OUT} = 0\text{ V}$	—	—	1	$\mu\text{A}$
	Low-side	$I_{OL}$	$V_M = V_{OUT} = 44\text{ V}$	1	—	—	$\mu\text{A}$
Motor current channel differential		$\Delta I_{OUT1}$	Current differential between Ch $I_{OUT} = 1.0\text{ A}$	-5	0	5	%
Motor current setting accuracy		$\Delta I_{OUT2}$	$I_{OUT} = 1.0\text{ A}$	-5	0	5	%
Motor output ON-resistance (High-side + Low-side)		$R_{ON(D-S)}$	$T_j = 25\text{ }^\circ\text{C}$ $I_{OUT} = 2.0\text{ A}$	—	0.4	0.52	$\Omega$

Note:  $V_{IN(H)}$  is defined as the  $V_{IN}$  voltage that changes the output voltage by being applied to the test pin and raising this voltage from 0V gradually.  $V_{IN(L)}$  is defined as the  $V_{IN}$  voltage that changes the output voltage by being applied to the test pin and lowering this voltage gradually. The difference between  $V_{IN(H)}$  and  $V_{IN(L)}$  is defined as  $V_{IN(HIS)}$ .

## 15.2. Electrical Specifications 2 ( $T_a = 25\text{ }^\circ\text{C}$ , $V_M = 24\text{ V}$ unless otherwise specified)

Table 15.2 Electrical Specifications 2

Characteristics	Symbol	Test condition	Min	Typ.	Max	Unit
$V_{ref}$ input current	$I_{REF}$	$V_{ref} = 3.3\text{ V}$	-3	—	3	$\mu\text{A}$
$V_{ref}$ decay ratio	$V_{REF(GAIN)}$	$V_{ref} = 2.0\text{ V}$	—	5	—	—
VREG voltage	$V_{REG}$	$I_{OUT} = 1.0\text{ mA}$	3.2	3.3	3.4	V
TSD threshold	$T_{JTSD}$	—	150	160	180	$^\circ\text{C}$
TSD hysteresis	$T_{TSDHYS}$	—	—	30	—	$^\circ\text{C}$
VM power ON reset voltage	$V_{MPOR}$	—	—	7.8	8.2	V
VM power ON reset hysteresis voltage	$V_{MPOR(HYS)}$	—	—	200	—	mV
Over current detection circuit operating current	$I_{SD}$	—	3.0	—	—	A

### 15.2.1. Back-EMF

While a motor is rotating, there is a timing at which power is fed back to the power supply. At that timing, the motor current recirculates back to the power supply due to the effect of the motor back-EMF.

If the power supply does not have enough sink capability, the power supply and output pins of the device might rise above the rated voltages. The magnitude of the motor back-EMF varies with usage conditions and motor characteristics. It must be fully verified that there is no risk that the TB67S580FNG or other components will be damaged or fail due to the motor back-EMF.

### 15.2.2. Cautions on Overcurrent Shutdown (ISD) and Thermal Shutdown (TSD)

The ISD and TSD circuits are only intended to provide temporary protection against irregular conditions such as an output short-circuit; they do not necessarily guarantee the complete IC safety.

If the device is used beyond the specified operating ranges, these circuits may not operate properly: then the device may be damaged due to an output short-circuit.

The ISD circuit is only intended to provide a temporary protection against an output short-circuit. If such a condition persists for a long time, the device may be damaged due to overstress. Overcurrent conditions must be removed immediately by external hardware.

### 15.2.3. IC Mounting

Do not insert devices incorrectly or in the wrong orientation. Otherwise, it may cause breakdown, damage and/or deterioration of the device.

## 16. AC Electrical Specification ( $T_a = 25\text{ }^\circ\text{C}$ , $V_M = 24\text{ V}$ )

Table 16 AC Electrical Specification

Characteristics	Symbol	Test condition	Min	Typ.	Max	Unit
Minimum clock pulse width	$t_{CLK(H)}$	—	1.9	—	—	$\mu\text{s}$
	$t_{CLK(L)}$	—	1.9	—	—	$\mu\text{s}$
Setup time	$t_{SU(STEP)}$	—	650	—	—	ns
Hold time	$t_{H(STEP)}$	—	650	—	—	ns
Enable time	$t_{ENBL}$	—	650	—	—	ns
Wakeup time	$t_{WAKE}$	—	—	—	10	ms
Output transistor switching characteristics	$t_r$	—	30	—	200	ns
	$t_f$	—	30	—	200	ns
Chopping frequency	$f_{CHOP}$	—	—	50	—	kHz
Blanking time of noise rejection	$t_{BLANK}$	—	—	3.75	—	$\mu\text{s}$
Dead band time of ISD	$t_{DEG}$	—	—	3	—	$\mu\text{s}$

### 16.1. AC Electrical Specification Timing chart

TB67S580FNG (CLK input control)

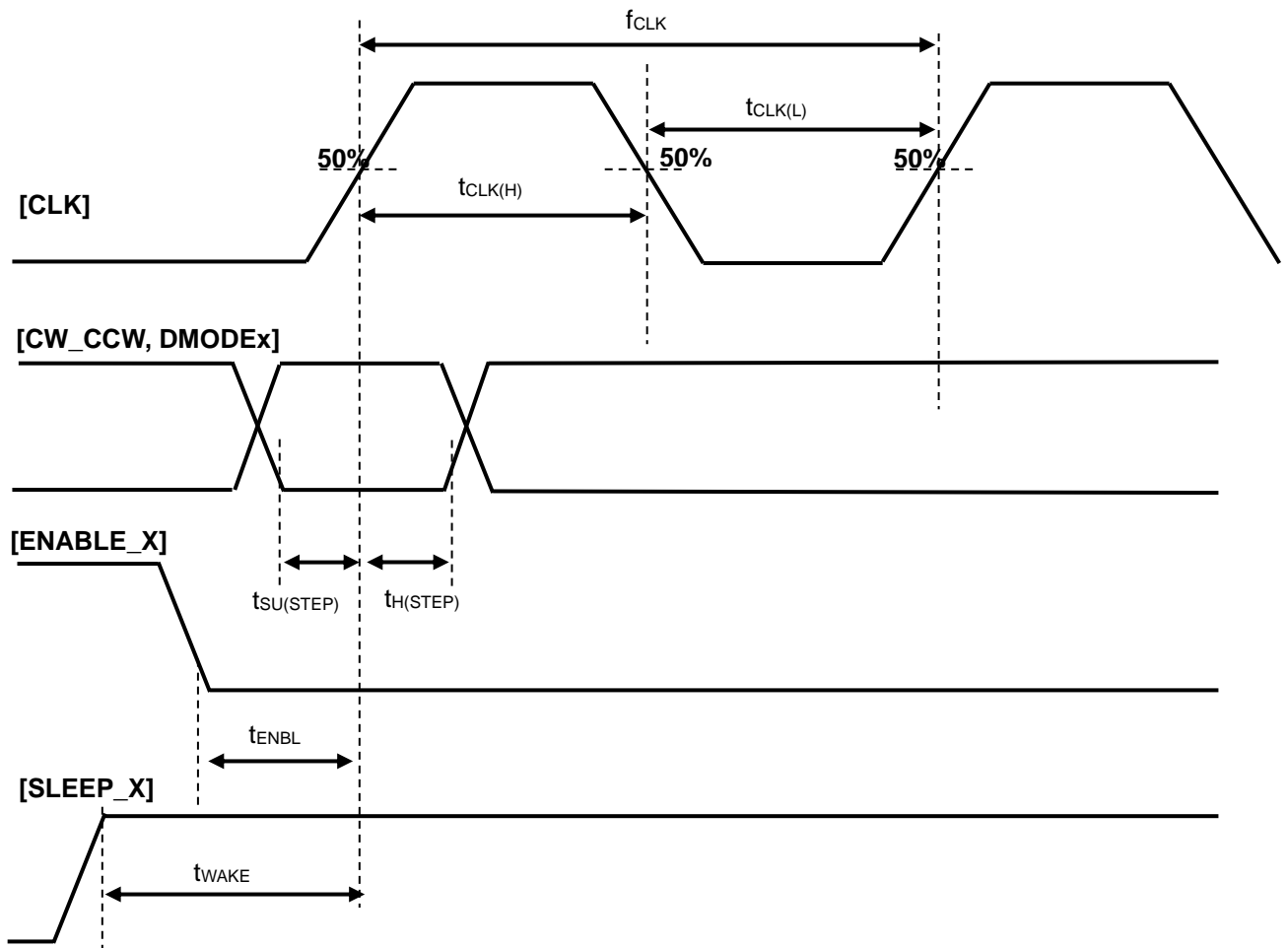

Figure16.1 AC Electrical Specification Timing chart



## 17. Application Circuit Example

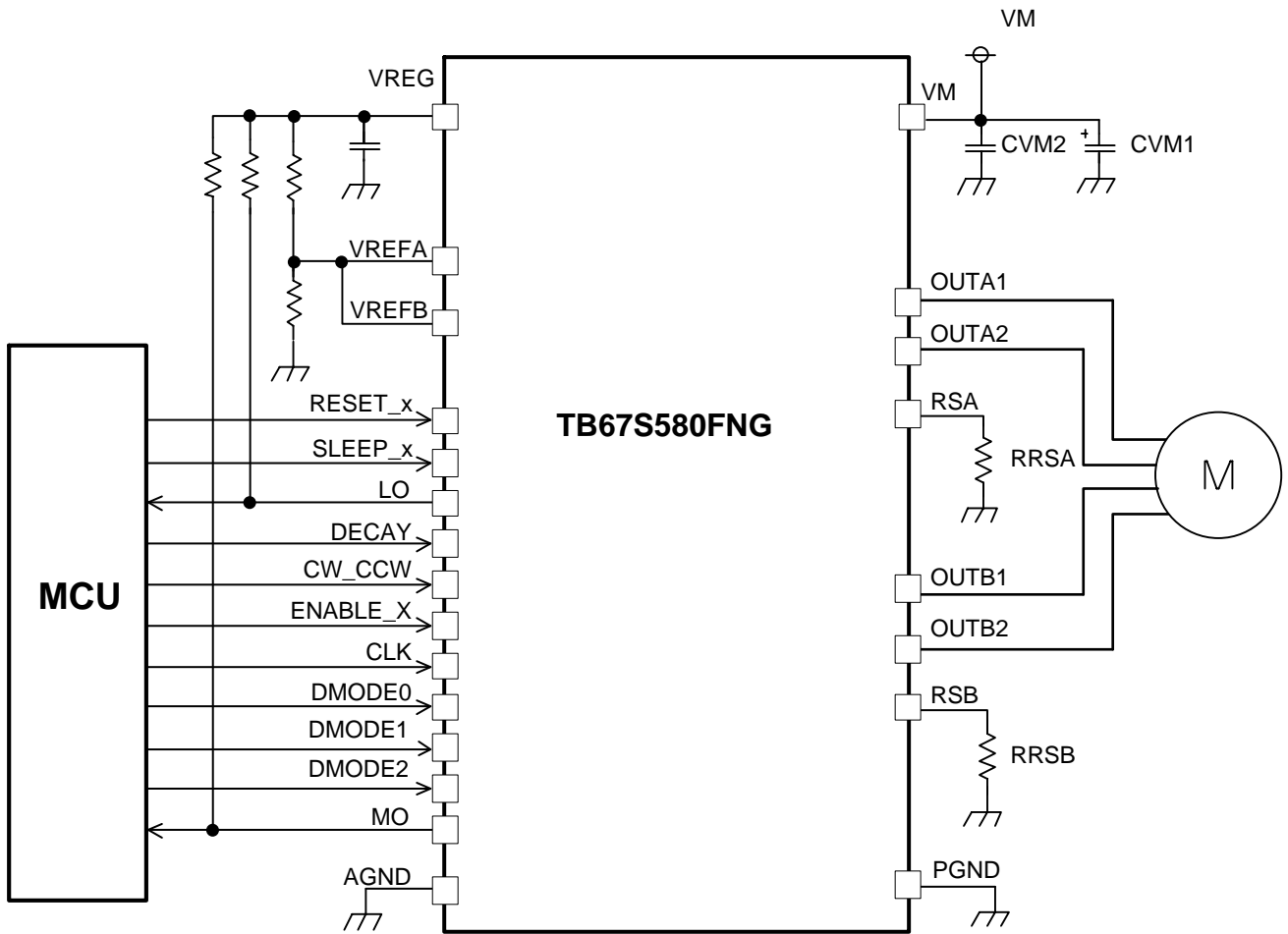
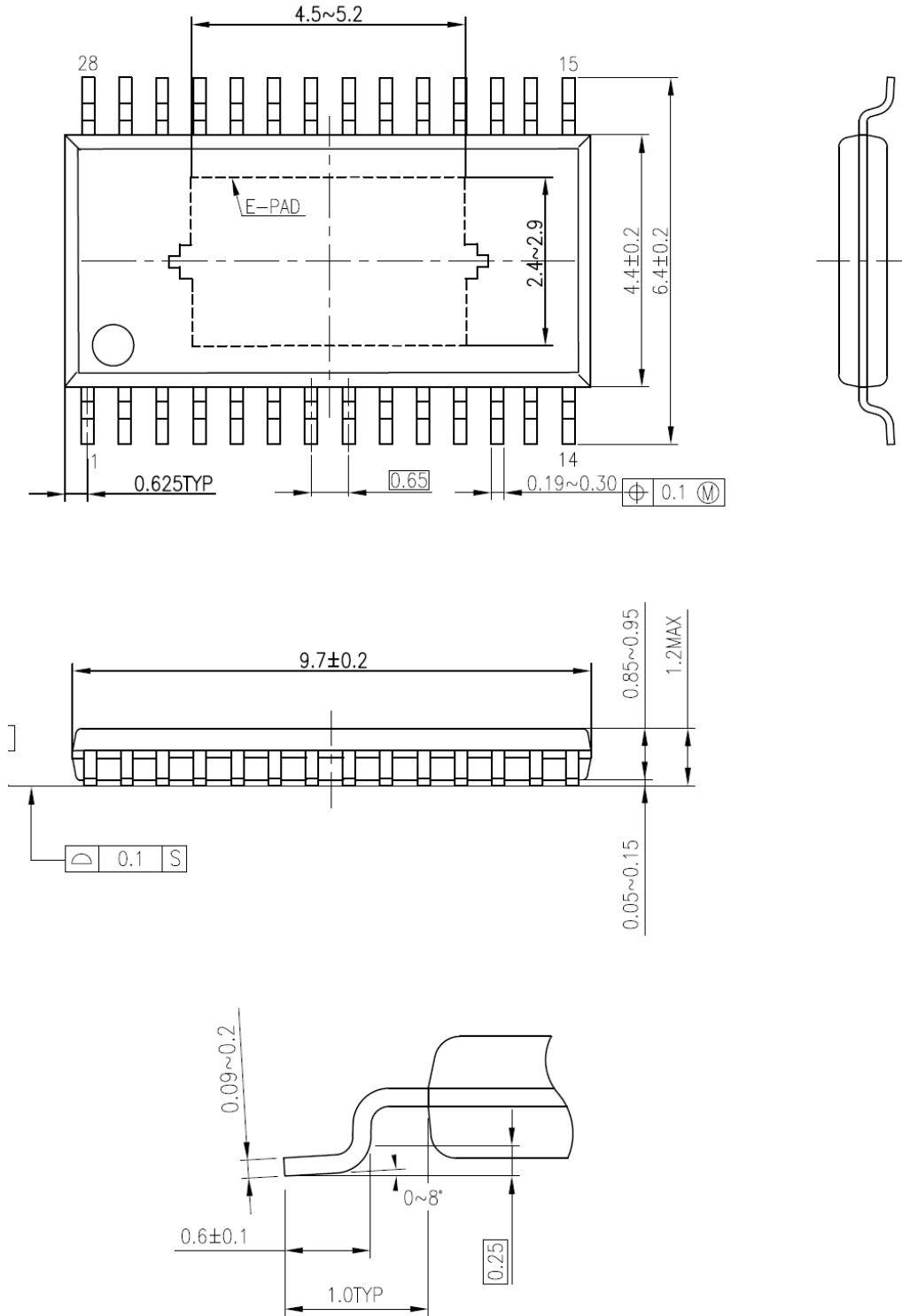

Figure17 Application Circuit Example

## 18. Package Dimensions

P-HTSSOP28-0510-0.65-001

Unit: mm



Weight: 0.105 g (Typ.)

Figure18 Package Dimensions

## 19. Notes on Contents

### Block Diagrams

Some of the functional blocks, circuits, or constants in the block diagram may be omitted or simplified for explanatory purposes.

### Timing Charts

Timing charts may be simplified for explanatory purposes.

### Application Circuits

The application circuits shown in this document are provided for reference purposes only. Thorough evaluation is required, especially at the mass production design stage.

Providing these application circuit examples does not grant a license for industrial property rights.

## 20. IC Usage Considerations

### 20.1. Notes on handling of ICs

- (1) The absolute maximum ratings of a semiconductor device are a set of ratings that must not be exceeded, even for a moment. Do not exceed any of these ratings.  
Exceeding the rating(s) may cause the device breakdown, damage or deterioration, and may result injury by explosion or combustion.
  
- (2) Use an appropriate power supply fuse to ensure that a large current does not continuously flow in case of over current and/or IC failure. The IC will fully break down when used under conditions that exceed its absolute maximum ratings, when the wiring is routed improperly or when an abnormal pulse noise occurs from the wiring or load, causing a large current to continuously flow and the breakdown can lead smoke or ignition. To minimize the effects of the flow of a large current in case of breakdown, appropriate settings, such as fuse capacity, fusing time and insertion circuit location, are required.
  
- (3) If your design includes an inductive load such as a motor coil, incorporate a protection circuit into the design to prevent device malfunction or breakdown caused by the current resulting from the inrush current at power ON or the negative current resulting from the back electromotive force at power OFF. IC breakdown may cause injury, smoke or ignition. Use a stable power supply with ICs with built-in protection functions. If the power supply is unstable, the protection function may not operate, causing IC breakdown. IC breakdown may cause injury, smoke or ignition.
  
- (4) Do not insert devices in the wrong orientation or incorrectly.  
Make sure that the positive and negative terminals of power supplies are connected properly. Otherwise, the current or power consumption may exceed the absolute maximum rating, and exceeding the rating(s) may cause the device breakdown, damage or deterioration, and may result injury by explosion or combustion. In addition, do not use any device that is applied the current with inserting in the wrong orientation or incorrectly even just one time.
  
- (5) Carefully select external components (such as inputs and negative feedback capacitors) and load components (such as speakers), for example, power amp and regulator. If there is a large amount of leakage current such as from input or negative feedback condenser, the IC output DC voltage will increase. If this output voltage is connected to a speaker with low input withstand voltage, overcurrent or IC failure may cause smoke or ignition. (The overcurrent may cause smoke or ignition from the IC itself.) In particular, please pay attention when using a Bridge Tied Load (BTL) connection-type IC that inputs output DC voltage to a speaker directly.

## 20.2. Points to remember on handling of ICs

### (1) Over current Protection Circuit

Over current protection circuits (referred to as current limiter circuits) do not necessarily protect ICs under all circumstances. If the Over current protection circuits operate against the over current, clear the over current status immediately.

Depending on the method of use and usage conditions, such as exceeding absolute maximum ratings can cause the over current protection circuit to not operate properly or IC breakdown before operation. In addition, depending on the method of use and usage conditions, if over current continues to flow for a long time after operation, the IC may generate heat resulting in breakdown.

### (2) Thermal Shutdown Circuit

Thermal shutdown circuits do not necessarily protect ICs under all circumstances. If the thermal shutdown circuits operate against the over temperature, clear the heat generation status immediately.

Depending on the method of use and usage conditions, such as exceeding absolute maximum ratings can cause the thermal shutdown circuit to not operate properly or IC breakdown before operation.

### (3) Heat Radiation Design

In using an IC with large current flow such as power amp, regulator or driver, please design the device so that heat is appropriately radiated, not to exceed the specified junction temperature ( $T_j$ ) at any time and condition.

These ICs generate heat even during normal use. An inadequate IC heat radiation design can lead to decrease in IC life, deterioration of IC characteristics or IC breakdown. In addition, please design the device taking into consideration the effect of IC heat radiation with peripheral components.

### (4) Back-EMF

When a motor reverses the rotation direction, stops or slows down abruptly, a current flow back to the motor's power supply due to the effect of back-EMF. If the current sink capability of the power supply is small, the device's motor power supply and output pins might be exposed to conditions beyond absolute maximum ratings. To avoid this problem, take the effect of back-EMF into consideration in system design.

## RESTRICTIONS ON PRODUCT USE

Toshiba Corporation and its subsidiaries and affiliates are collectively referred to as "TOSHIBA". Hardware, software and systems described in this document are collectively referred to as "Product".

- TOSHIBA reserves the right to make changes to the information in this document and related Product without notice.
- This document and any information herein may not be reproduced without prior written permission from TOSHIBA. Even with TOSHIBA's written permission, reproduction is permissible only if reproduction is without alteration/omission.
- Though TOSHIBA works continually to improve Product's quality and reliability, Product can malfunction or fail. Customers are responsible for complying with safety standards and for providing adequate designs and safeguards for their hardware, software and systems which minimize risk and avoid situations in which a malfunction or failure of Product could cause loss of human life, bodily injury or damage to property, including data loss or corruption. Before customers use the Product, create designs including the Product, or incorporate the Product into their own applications, customers must also refer to and comply with (a) the latest versions of all relevant TOSHIBA information, including without limitation, this document, the specifications, the data sheets and application notes for Product and the precautions and conditions set forth in the "TOSHIBA Semiconductor Reliability Handbook" and (b) the instructions for the application with which the Product will be used with or for. Customers are solely responsible for all aspects of their own product design or applications, including but not limited to (a) determining the appropriateness of the use of this Product in such design or applications; (b) evaluating and determining the applicability of any information contained in this document, or in charts, diagrams, programs, algorithms, sample application circuits, or any other referenced documents; and (c) validating all operating parameters for such designs and applications. **TOSHIBA ASSUMES NO LIABILITY FOR CUSTOMERS' PRODUCT DESIGN OR APPLICATIONS.**
- **PRODUCT IS NEITHER INTENDED NOR WARRANTED FOR USE IN EQUIPMENTS OR SYSTEMS THAT REQUIRE EXTRAORDINARILY HIGH LEVELS OF QUALITY AND/OR RELIABILITY, AND/OR A MALFUNCTION OR FAILURE OF WHICH MAY CAUSE LOSS OF HUMAN LIFE, BODILY INJURY, SERIOUS PROPERTY DAMAGE AND/OR SERIOUS PUBLIC IMPACT ("UNINTENDED USE").** Except for specific applications as expressly stated in this document, Unintended Use includes, without limitation, equipment used in nuclear facilities, equipment used in the aerospace industry, lifesaving and/or life supporting medical equipment, equipment used for automobiles, trains, ships and other transportation, traffic signaling equipment, equipment used to control combustions or explosions, safety devices, elevators and escalators, and devices related to power plant. **IF YOU USE PRODUCT FOR UNINTENDED USE, TOSHIBA ASSUMES NO LIABILITY FOR PRODUCT.** For details, please contact your TOSHIBA sales representative or contact us via our website.
- Do not disassemble, analyze, reverse-engineer, alter, modify, translate or copy Product, whether in whole or in part.
- Product shall not be used for or incorporated into any products or systems whose manufacture, use, or sale is prohibited under any applicable laws or regulations.
- The information contained herein is presented only as guidance for Product use. No responsibility is assumed by TOSHIBA for any infringement of patents or any other intellectual property rights of third parties that may result from the use of Product. No license to any intellectual property right is granted by this document, whether express or implied, by estoppel or otherwise.
- **ABSENT A WRITTEN SIGNED AGREEMENT, EXCEPT AS PROVIDED IN THE RELEVANT TERMS AND CONDITIONS OF SALE FOR PRODUCT, AND TO THE MAXIMUM EXTENT ALLOWABLE BY LAW, TOSHIBA (1) ASSUMES NO LIABILITY WHATSOEVER, INCLUDING WITHOUT LIMITATION, INDIRECT, CONSEQUENTIAL, SPECIAL, OR INCIDENTAL DAMAGES OR LOSS, INCLUDING WITHOUT LIMITATION, LOSS OF PROFITS, LOSS OF OPPORTUNITIES, BUSINESS INTERRUPTION AND LOSS OF DATA, AND (2) DISCLAIMS ANY AND ALL EXPRESS OR IMPLIED WARRANTIES AND CONDITIONS RELATED TO SALE, USE OF PRODUCT, OR INFORMATION, INCLUDING WARRANTIES OR CONDITIONS OF MERCHANTABILITY, FITNESS FOR A PARTICULAR PURPOSE, ACCURACY OF INFORMATION, OR NONINFRINGEMENT.**
- Do not use or otherwise make available Product or related software or technology for any military purposes, including without limitation, for the design, development, use, stockpiling or manufacturing of nuclear, chemical, or biological weapons or missile technology products (mass destruction weapons). Product and related software and technology may be controlled under the applicable export laws and regulations including, without limitation, the Japanese Foreign Exchange and Foreign Trade Law and the U.S. Export Administration Regulations. Export and re-export of Product or related software or technology are strictly prohibited except in compliance with all applicable export laws and regulations.
- Please contact your TOSHIBA sales representative for details as to environmental matters such as the RoHS compatibility of Product. Please use Product in compliance with all applicable laws and regulations that regulate the inclusion or use of controlled substances, including without limitation, the EU RoHS Directive. **TOSHIBA ASSUMES NO LIABILITY FOR DAMAGES OR LOSSES OCCURRING AS A RESULT OF NONCOMPLIANCE WITH APPLICABLE LAWS AND REGULATIONS.**